

PISTON & BALL CHECK VALVES

Full die forged structure for all pressure containing parts.

Flanged valves are provided with flanges integral with the body forgings.

Standard construction of body-bonnet connections is bolted bonnet type. Welded bonnet is available as alternative construction.

Sealing surfaces are machined to the tightest tolerances and lowest roughness to ensure trouble free shut off.

Standard gasket design for bolted-bonnet valves is spiral wound type up to class ASME 1500. Ring Joint gaskets are standard for ASME 2500 and above. SPW/RJ are available on request for all pressure classes as option.

Body-guided disc for perfect seat and disc alignment. Disc is machined to the tightest tolerances to ensure trouble free shutoff and cycling.

Precision guided closure member for perfect seating surfaces alignment.

Closure member can be spring loaded for positive closure in any position.

High flow capacity port sizes and disc retraction to minimize flow velocities and maximize valve service life.

Low cracking pressure design.

Fast response time to prevent backflow and adequate valve seating to prevent seat slamming.

Standard seat design is screwed-in type, integral type is available as alternative construction or in case of bolted bonnet design. Extra thickness of the seat ring provides sufficient material to renew the seating surface over and over again.

PISTON & BALL CHECK VALVE DESCRIPTION

Piston and ball check valves, like all check valves, are used to prevent back flow in the line. Standard valve design has no spring in order to minimize cracking pressure and pressure drop, it will only function properly when installed in a horizontal line. As an option the designs can include a spring to assist closing and for use in 90-degree styles installed in vertical lines.

PISTON CHECK VALVE

The pressure of the fluid passing through a system opens the valve, while any reversal of flow will close the valve. In Piston, or lift, check valves a body-guided disc moves within the body bore. The body guide ensures alignment of the seat and disc when the valve closes. The valve is installed with the flow under the disc, so that the inlet line pressure and flow rate will force the disc to "lift" off the seat and allow the line fluid to flow through the valve. Should the flow suddenly reverse itself, the disc will automatically and quickly, assisted by the weight of the disc, be forced to the closed position, preventing the line fluid from returning. Exercise caution when these valves are used for dirty media because that media could cause the disc to stick inside the body bore.

BALL CHECK VALVE

The function of ball check valves is similar to the piston check, but the ball check valves use a "ball" inside the body to control the movement of flow. The ball is free to rotate, resulting in even wear and a wiping action between the ball and seat. This feature makes ball checks useful for viscous media.













P&ID SYMBOL



STANDARD CONFIGURATIONS



SECTION INDEX OF PISTON AND BALL CHECK VALVES

PAGE	DESCRIPTION	SYM
F-3	BOLTED BONNET PISTON & BALL CHECK VALVES BASIC CONFIGURATION	
	 THREADED AND SOCKET WELD ENDS	
F-4	BOLTED BONNET PISTON & BALL CHECK VALVES BASIC CONFIGURATION	
	 ASME INTEGRAL FLANGED ENDS	
F-5	WELDED BONNET PISTON & BALL CHECK VALVES BASIC CONFIGURATION	
	 THREADED AND SOCKET WELD ENDS	
F-6	WELDED BONNET PISTON & BALL CHECK VALVES BASIC CONFIGURATION	
	 ASME INTEGRAL FLANGED ENDS	
F-7	AVAILABLE OPTIONS FOR PISTON & BALL CHECK VALVES	



Global Supply Line Australia major Bonney Forge distributor & stockist, supplying world wide.
Full stock list online www.globalsupplyline.com.au

Contact email: sales@globalsupplyline.com.au

APPLICABLE STANDARDS	
DESIGN	API 602 - ISO 15761 - ASME B16.34
INSPECTION & TESTING	API 598
MARKING	MSS SP-25
RATING	ASME B16.34
FUGITIVE EMISSION	API 624 - ISO 15848

PISTON & BALL CHECK VALVES

BOLTED BONNET PISTON & BALL CHECK VALVES BASIC CONFIGURATION THREADED AND SOCKET WELD ENDS



WORKING PRESSURE RATING	SIZE		STANDARD DESIGN TYPE	A		B		H		WEIGHT		FIGURE PISTON CHECK	FIGURE BALL CHECK
	NPS	DN		mm	in	mm	in	mm	in	kg	lb		
ASME 800	1/2"	15	S1	80	3.15	9	0.35	55	2.17	1.3	2.9	HL 403	HL 503
	3/4"	20	S1	90	3.54	13	0.51	60	2.36	1.6	3.5	HL 404	HL 504
	1"	25	S1	110	4.33	17	0.66	78	3.07	2.8	6.2	HL 405	HL 505
	1-1/2"	40	S1	150	5.91	29	1.14	92	3.62	5.6	12.3	HL 407	HL 507
	2"	50	S1	180	7.09	35	1.38	108	4.25	9	19.8	HL 408	HL 508
ASME 1500	1/2"	15	S1	90	3.54	9	0.35	60	2.36	1.7	3.7	9HL 403	9HL 503
	3/4"	20	S1	110	4.33	12	0.47	78	3.07	3	6.6	9HL 404	9HL 504
	1"	25	S1	127	5.00	15	0.59	88	3.46	4.4	9.7	9HL 405	9HL 505
	1-1/2"	40	S1	180	7.09	27	1.06	108	4.25	10	22.0	9HL 407	9HL 507
	2"	50	S1	210	8.27	32	1.26	145	5.71	18	39.7	9HL 408	9HL 508
ASME 800	1/4"	6	S1	80	3.15	7	0.28	55	2.17	1.4	3.1	H 401	H 501
	3/8"	10	S1	80	3.15	9	0.35	55	2.17	1.4	3.1	H 402	H 502
	1/2"	15	S1	90	3.54	13	0.51	60	2.36	1.6	3.5	H 403	H 503
	3/4"	20	S1	110	4.33	17	0.66	78	3.07	3	6.6	H 404	H 504
	1"	25	S1	127	5.00	22	0.86	88	3.46	4.3	9.5	H 405	H 505
	1-1/4"	32	S1	150	5.91	29	1.14	92	3.62	5.6	12.3	H 406	H 506
	1-1/2"	40	S1	180	7.09	35	1.38	108	4.25	10	22.0	H 407	H 507
ASME 1500	1/4"	6	S1	90	3.54	7	0.28	60	2.36	1.7	3.7	9H 401	9H 501
	3/8"	10	S1	90	3.54	9	0.35	60	2.36	1.7	3.7	9H 402	9H 502
	1/2"	15	S1	110	4.33	12	0.47	78	3.07	3.1	6.8	9H 403	9H 503
	3/4"	20	S1	127	5.00	15	0.59	88	3.46	4.6	10.1	9H 404	9H 504
	1"	25	S1	150	5.91	20	0.79	92	3.62	6.5	14.3	9H 405	9H 505
	1-1/4"	32	S1	180	7.09	27	1.06	108	4.25	10.6	23.4	9H 406	9H 506
	1-1/2"	40	S1	210	8.27	32	1.26	145	5.71	19	41.9	9H 407	9H 507
ASME 2500	1/2"	15	S2	150	5.91	11	0.43	128	5.04	7.5	16.5	25HR 403	25HR 503
	3/4"	20	S2	150	5.91	14.5	0.57	128	5.04	7.5	16.5	25HR 404	25HR 504
	1"	25	S2	210	8.27	19	0.75	152	5.98	18.5	40.8	25HR 405	25HR 505
	1-1/2"	40	S2	230	9.06	28	1.10	190	7.48	30	66.1	25HR 407	25HR 507
	2"	50	S2	230	9.06	38	1.50	190	7.48	30	66.1	25HR 408	25HR 508

BFE reserves the right to change designs, dimensions or specifications without notice.

PRODUCT FEATURES:

- Body-Bonnet weld to ASME IX

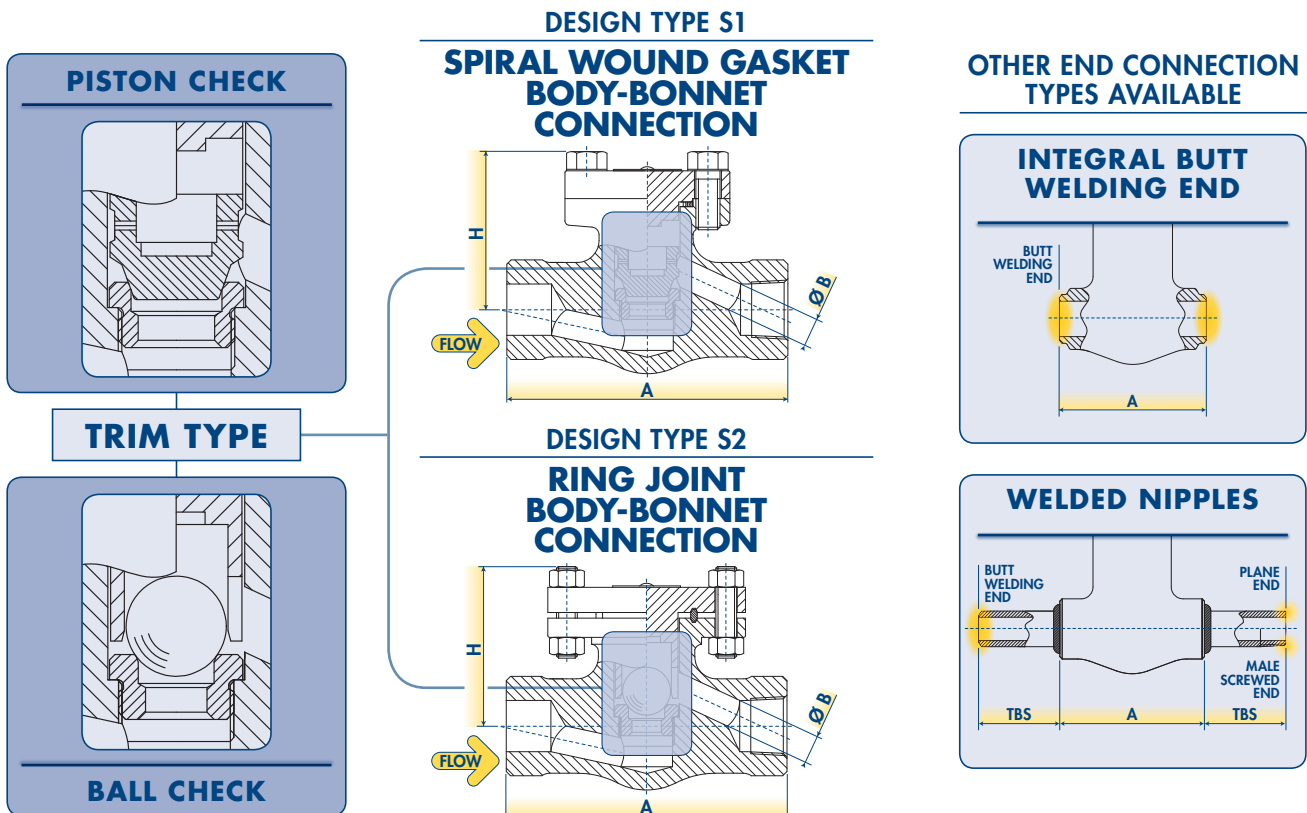

PISTON & BALL CHECK VALVES

BOLTED BONNET PISTON & BALL CHECK VALVES BASIC CONFIGURATION ASME INTEGRAL FLANGED ENDS



WORKING PRESSURE RATING	SIZE		STANDARD DESIGN TYPE	A-RF		A-RJ		B		H		WEIGHT		FIGURE PISTON CHECK	FIGURE BALL CHECK		
	NPS	DN		mm	in	mm	in	mm	in	mm	in	kg	lb				
ASME 150	1/2"	15	S1	108	4.25	N.A.	N.A.	10	0.39	75	3.0	2.3	5.1	L1-403	L1-503	STANDARD BORE	
	3/4"	20	S1	117.5	4.63	N.A.	N.A.	14	0.55	75	3.0	3.1	6.8	L1-404	L1-504		
	1"	25	S1	127	5.00	140	5.51	17	0.66	85	3.3	4.5	9.9	L1-405	L1-505		
	1-1/2"	40	S1	165	6.50	178	7.01	29	1.14	110	4.3	8.4	18.5	L1-407	L1-507		
	2"	50	S1	203	7.99	216	8.50	35	1.38	125	4.9	14	30.9	L1-408	L1-508		
ASME 300	1/2"	15	S1	152.5	6.00	163.6	6.44	9	0.35	75	3.0	3.4	7.5	L3-403	L3-503		STANDARD BORE
	3/4"	20	S1	178	7.01	190.5	7.50	13	0.51	80	3.1	5.3	11.7	L3-404	L3-504		
	1"	25	S1	203	7.99	216	8.50	17	0.66	88	3.5	7.5	16.5	L3-405	L3-505		
	1-1/2"	40	S1	229	9.02	241	9.49	29	1.14	115	4.5	14	30.9	L3-407	L3-507		
	2"	50	S1	267	10.51	282.5	11.12	35	1.38	130	5.1	19	41.9	L3-408	L3-508		
ASME 600	1/2"	15	S1	165	6.50	163.5	6.44	9	0.35	72	2.8	3.5	7.7	L6-403	L6-503	STANDARD BORE	
	3/4"	20	S1	191	7.52	190.5	7.50	13	0.51	80	3.1	5.7	12.6	L6-404	L6-504		
	1"	25	S1	216	8.50	216	8.50	17	0.66	85	3.3	8	17.6	L6-405	L6-505		
	1-1/2"	40	S1	241	9.49	241	9.49	29	1.14	115	4.5	14.5	32.0	L6-407	L6-507		
	2"	50	S1	292	11.50	295	11.61	35	1.38	130	5.1	19.5	43.0	L6-408	L6-508		
ASME 1500	1/2"	15	S1	216	8.50	216	8.50	9	0.35	85	3.3	6.5	14.3	15FL 403	15FL 503		STANDARD BORE
	3/4"	20	S1	229	9.02	229	9.02	14	0.55	100	3.9	10.2	22.5	15FL 404	15FL 504		
	1"	25	S1	254	10.00	254	10.00	14	0.55	105	4.1	13.5	29.8	15FL 405	15FL 505		
	1-1/2"	40	S1	305	12.01	305	12.01	26	1.02	125	4.9	25.5	56.2	15FL 407	15FL 507		
	2"	50	S1	368	14.49	371.5	14.63	34	1.34	165	6.5	49	108.0	15FL 408	15FL 508		
ASME 150	1/2"	15	S1	108	4.25	N.A.	N.A.	13	0.51	75	3.0	2.8	6.2	1-403	1-503	FULL BORE	
	3/4"	20	S1	117.5	4.63	N.A.	N.A.	17.5	0.69	85	3.3	3.6	7.9	1-404	1-504		
	1"	25	S1	127	5.00	140	5.51	22.5	0.89	100	3.9	5.2	11.5	1-405	1-505		
	1-1/2"	40	S1	165	6.50	178	7.01	35	1.38	125	4.9	10	22.0	1-407	1-507		
	2"	50	S1	203	7.99	216	8.50	45	1.77	140	5.5	16	35.3	1-408	1-508		
ASME 300	1/2"	15	S1	152.5	6.00	163.5	6.44	13	0.51	75	3.0	3.6	7.9	3-403	3-503		FULL BORE
	3/4"	20	S1	178	7.01	190.5	7.50	17.5	0.69	90	3.5	6.4	14.1	3-404	3-504		
	1"	25	S1	203	7.99	216	8.50	22.5	0.89	100	3.9	8.2	18.1	3-405	3-505		
	1-1/2"	40	S1	229	9.02	241	9.49	35	1.38	120	4.7	15	33.1	3-407	3-507		
	2"	50	S1	267	10.51	282.5	11.12	45	1.77	150	5.9	21	46.3	3-408	3-508		
ASME 600	1/2"	15	S1	165	6.50	163.5	6.44	13	0.51	75	3.0	3.8	8.4	6-403	6-503	FULL BORE	
	3/4"	20	S1	191	7.52	190.5	7.50	17.5	0.69	90	3.5	6.5	14.3	6-404	6-504		
	1"	25	S1	216	8.50	216	8.50	22.5	0.89	100	3.9	8.5	18.7	6-405	6-505		
	1-1/2"	40	S1	241	9.49	241	9.49	35	1.38	120	4.7	16	35.3	6-407	6-507		
	2"	50	S1	292	11.50	295	11.61	45	1.77	150	5.9	23	50.7	6-408	6-508		
ASME 1500	1/2"	15	S1	216	8.50	216	8.50	12	0.47	99	3.9	6.5	14.3	15F 403	15F 503		FULL BORE
	3/4"	20	S1	229	9.02	229	9.02	14.5	0.57	119	4.7	10.2	22.5	15F 404	15F 504		
	1"	25	S1	254	10.00	254	10.00	19	0.75	129	5.1	13.5	29.8	15F 405	15F 505		
	1-1/2"	40	S1	305	12.01	305	12.01	31	1.22	149	5.9	25.5	56.2	15F 407	15F 507		
	2"	50	S1	368	14.49	371.5	14.63	38	1.50	189	7.4	49	108.0	15F 408	15F 508		
ASME 2500	1/2"	15	S2	264	10.39	264	10.39	11	0.43	122	4.8	13.3	29.3	25RF 403	25RF 503	FULL BORE	
	3/4"	20	S2	273	10.75	273	10.75	14.5	0.57	124	4.9	15	33.1	25RF 404	25RF 504		
	1"	25	S2	308	12.13	308	12.13	19	0.75	146	5.7	25.3	55.8	25RF 405	25RF 505		
	1-1/2"	40	S2	384	15.12	387	15.24	28	1.10	182	7.2	53	116.8	25RF 407	25RF 507		
	2"	50	S2	451	17.76	454	17.87	35	1.38	184	7.2	55	121.3	25RF 408	25RF 508		

BPE reserves the right to change designs, dimensions or specifications without notice.

PRODUCT FEATURES:

- Outside Screw and Yoke (OS&Y).
- Self aligning two piece packing gland.
- Integral backseat.
- Integral body flanges.

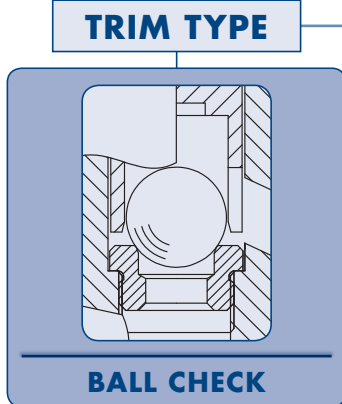
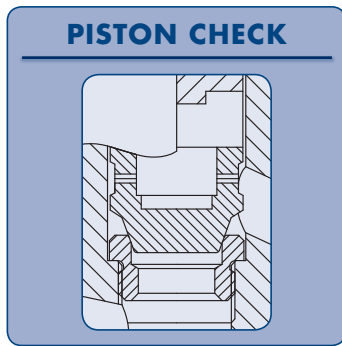

TRIM TYPE

DESIGN TYPE S1 SPIRAL WOUND GASKET BODY-BONNET CONNECTION

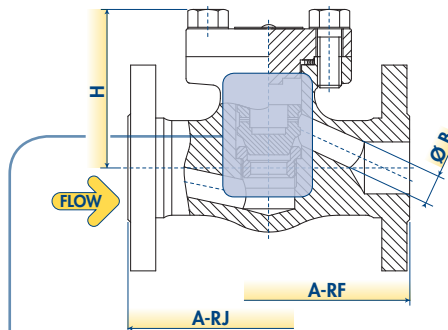

DESIGN TYPE S2 RING JOINT BODY-BONNET CONNECTION

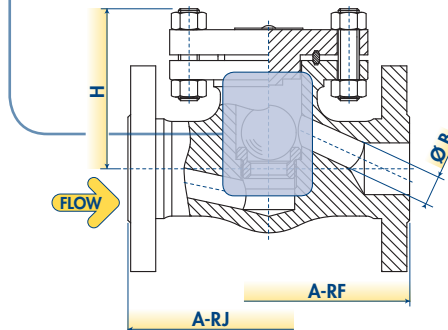

PISTON & BALL CHECK VALVES

WELDED BONNET PISTON & BALL CHECK VALVES BASIC CONFIGURATION THREADED AND SOCKET WELD ENDS



WORKING PRESSURE RATING	SIZE		STANDARD DESIGN TYPE	A		B		H		WEIGHT		FIGURE PISTON CHECK	FIGURE BALL CHECK		
	NPS	DN		mm	in	mm	in	mm	in	kg	lb				
ASME 800	1/2"	15	W1 / W3	80	3.15	9	0.35	54	2.13	0.9	2.0	WL 403	HWL 503	STANDARD BORE	
	3/4"	20	W1 / W3	90	3.54	13	0.51	60	2.36	1.1	2.4	WL 404	HWL 504		
	1"	25	W1 / W3	110	4.33	17	0.66	76	2.99	2.3	5.1	WL 405	HWL 505		
	1-1/2"	40	W1 / W3	150	5.91	29	1.14	92	3.62	5	11.0	WL 407	HWL 507		
	2"	50	W1 / W3	180	7.09	35	1.38	110	4.33	8.3	18.3	WL 408	HWL 508		
ASME 1500	1/2"	15	W1 / W3	90	3.54	9	0.35	54	2.13	1.4	3.1	9WL 403	9HWL 503		
	3/4"	20	W1 / W3	110	4.33	12	0.47	76	2.99	2.2	4.9	9WL 404	9HWL 504		
	1"	25	W1 / W3	127	5.00	15	0.59	86	3.39	3	6.6	9WL 405	9HWL 505		
	1-1/2"	40	W1 / W3	180	7.09	27	1.06	110	4.33	9.6	21.2	9WL 407	9HWL 507		
	2"	50	W1 / W3	210	8.27	32	1.26	150	5.91	16	35.3	9WL 408	9HWL 508		
ASME 800	1/4"	6	W1 / W3	80	3.15	7	0.28	55	2.17	1	2.2	W 401	HW 501		FULL BORE
	3/8"	10	W1 / W3	80	3.15	9	0.35	55	2.17	1	2.2	W 402	HW 502		
	1/2"	15	W1 / W3	90	3.54	13	0.51	60	2.36	1.2	2.6	W 403	HW 503		
	3/4"	20	W1 / W3	110	4.33	17	0.66	78	3.07	2.3	5.1	W 404	HW 504		
	1"	25	W1 / W3	127	5.00	22	0.86	88	3.46	3.3	7.3	W 405	HW 505		
	1-1/4"	32	W1 / W3	150	5.91	29	1.14	92	3.62	5.2	11.5	W 406	HW 506		
	1-1/2"	40	W1 / W3	180	7.09	35	1.38	110	4.33	8.7	19.2	W 407	HW 507		
2"	50	W1 / W3	210	8.27	45	1.77	150	5.91	14	30.9	W 408	HW 508			
ASME 1500	1/4"	6	W1 / W3	90	3.54	7	0.28	55	2.17	1.4	3.1	9W 401	9HW 501		
	3/8"	10	W1 / W3	90	3.54	9	0.35	55	2.17	1.4	3.1	9W 402	9HW 502		
	1/2"	15	W1 / W3	110	4.33	12	0.47	76	2.99	2.5	5.5	9W 403	9HW 503		
	3/4"	20	W1 / W3	127	5.00	15	0.59	84	3.31	3.7	8.2	9W 404	9HW 504		
	1"	25	W1 / W3	150	5.91	20	0.79	90	3.54	6	13.2	9W 405	9HW 505		
	1-1/4"	32	W1 / W3	180	7.09	27	1.06	110	4.33	10	22.0	9W 406	9HW 506		
	1-1/2"	40	W1 / W3	210	8.27	32	1.26	150	5.91	15.5	34.2	9W 407	9HW 507		
2"	50	W1 / W3	210	8.27	43	1.69	230	9.06	22	48.5	9W 408	9HW 508			
ASME 2500	1/4"	6	W2 / W3	90	3.54	7	0.28	70	2.76	3.2	7.1	25W 401	25HW 501		
	3/8"	10	W2 / W3	90	3.54	9	0.35	70	2.76	3.2	7.1	25W 402	25HW 502		
	1/2"	15	W2 / W3	110	4.33	11	0.43	86	3.39	3.8	8.4	25W 403	25HW 503		
	3/4"	20	W2 / W3	127	5.00	14.5	0.57	92	3.62	5.6	12.3	25W 404	25HW 504		
	1"	25	W2 / W3	180	7.09	19	0.75	110	4.33	10	22.0	25W 405	25HW 505		
	1-1/2"	40	W2 / W3	210	8.27	29	1.14	150	5.91	16	35.3	25W 407	25HW 507		
	2"	50	W2 / W3	230	9.06	38	1.50	180	7.09	21	46.3	25W 408	25HW 508		
ASME 4500	1/4"	6	W2 / W3	127	5.00	7	0.28	90	3.54	3.9	8.6	45W 401	45HW 501		
	3/8"	10	W2 / W3	127	5.00	7	0.28	90	3.54	3.9	8.6	45W 402	45HW 502		
	1/2"	15	W2 / W3	127	5.00	8	0.31	90	3.54	3.9	8.6	45W 403	45HW 503		
	3/4"	20	W2 / W3	180	7.09	11	0.43	110	4.33	10.5	23.1	45W 404	45HW 504		
	1"	25	W2 / W3	180	7.09	14	0.55	110	4.33	10.5	23.1	45W 405	45HW 505		
	1-1/2"	40	W2 / W3	230	9.06	25	0.98	180	7.09	25.2	55.6	45W 407	45HW 507		
	2"	50	W2 / W3	230	9.06	32	1.26	195	7.68	27	59.5	45W 408	45HW 508		

BFC reserves the right to change designs, dimensions or specifications without notice.

PRODUCT FEATURES:

- Outside Screw and Yoke (OS&Y).
- Self aligning two piece packing gland.
- Integral backseat.

DESIGN TYPE W1 V-GROOVE SEAL WELD BODY-BONNET CONNECTION

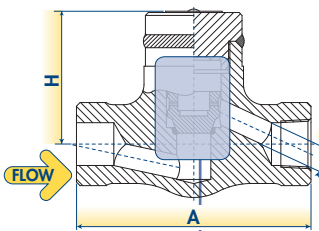

DESIGN TYPE W2 TEE JOINT FILLET WELD BODY-BONNET CONNECTION

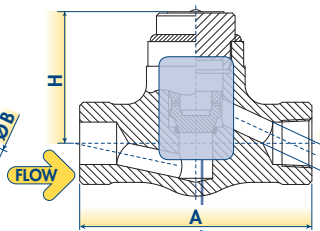

DESIGN TYPE W3 FULL PENETRATION WELD BODY-BONNET CONNECTION

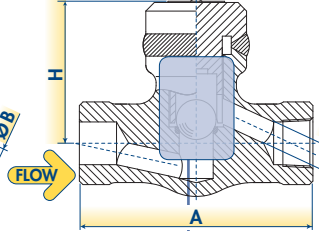

OTHER END CONNECTION TYPES AVAILABLE

INTEGRAL BUTT WELDING END

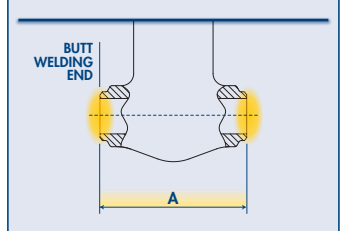

PISTON CHECK

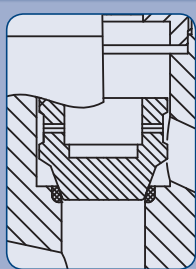

BALL CHECK

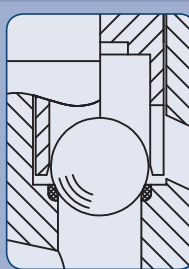

TRIM TYPE

WELDED NIPPLES

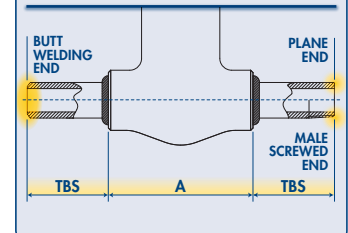

PISTON & BALL CHECK VALVES

WELDED BONNET PISTON & BALL CHECK VALVES BASIC CONFIGURATION ASME INTEGRAL FLANGED ENDS



WORKING PRESSURE RATING	SIZE		STANDARD DESIGN TYPE	A-RF		A-RJ		B		H		WEIGHT		FIGURE PISTON CHECK	FIGURE BALL CHECK	
	NPS	DN		mm	in	mm	in	mm	in	mm	in	kg	lb			
ASME 150	1/2"	15	W3	108	4.25	N.A.	N.A.	10	0.39	75	3.0	2.1	4.6	1HWL 403	1HWL 503	STANDARD BORE
	3/4"	20	W3	117.5	4.63	N.A.	N.A.	14	0.55	75	3.0	2.9	6.5	1HWL 404	1HWL 504	
	1"	25	W3	127	5.00	140	5.50	17	0.66	85	3.3	4.2	9.2	1HWL 405	1HWL 505	
	1-1/2"	40	W3	165	6.50	178	7.00	29	1.14	110	4.3	7.9	17.4	1HWL 407	1HWL 507	
	2"	50	W3	203	7.99	216	8.49	35	1.38	125	4.9	12.4	27.2	1HWL 408	1HWL 508	
ASME 300	1/2"	15	W3	152.5	6.00	163.5	6.44	9	0.35	75	3.0	3.1	6.9	3HWL 403	3HWL 503	
	3/4"	20	W3	178	7.01	190.5	7.51	13	0.51	80	3.1	4.9	10.9	3HWL 404	3HWL 504	
	1"	25	W3	203	7.99	216	8.49	17	0.66	88	3.5	7.0	15.5	3HWL 405	3HWL 505	
	1-1/2"	40	W3	229	9.02	241	9.52	29	1.14	115	4.5	12.8	28.3	3HWL 407	3HWL 507	
	2"	50	W3	267	10.51	282.5	11.13	35	1.38	130	5.1	18.1	39.8	3HWL 408	3HWL 508	
ASME 600	1/2"	15	W3	165	6.50	163.5	6.44	9	0.35	72	2.8	3.3	7.3	6HWL 403	6HWL 503	
	3/4"	20	W3	191	7.52	190.5	7.52	13	0.51	80	3.1	5.4	11.9	6HWL 404	6HWL 504	
	1"	25	W3	216	8.50	216	8.50	17	0.66	85	3.3	7.6	16.8	6HWL 405	6HWL 505	
	1-1/2"	40	W3	241	9.49	241	9.49	29	1.14	115	4.5	13.8	30.4	6HWL 407	6HWL 507	
	2"	50	W3	292	11.50	295	11.62	35	1.38	130	5.1	18.5	40.8	6HWL 408	6HWL 508	
ASME 1500	1/2"	15	W3	216	8.50	216	8.50	9	0.35	75	3.0	3.6	8.0	15HWLF 403	15HWLF 503	
	3/4"	20	W3	229	9.02	229	9.02	14	0.55	90	3.5	6.2	13.6	15HWLF 404	15HWLF 504	
	1"	25	W3	254	10.00	254	10.00	14	0.55	100	3.9	8.1	17.8	15HWLF 405	15HWLF 505	
	1-1/2"	40	W3	305	12.01	305	12.01	26	1.02	120	4.7	15.2	33.5	15HWLF 407	15HWLF 507	
	2"	50	W3	368	14.49	371.5	14.61	34	1.34	150	5.9	21.9	48.2	15HWLF 408	15HWLF 508	
ASME 150	1/2"	15	W3	108	4.25	N.A.	N.A.	13	0.51	75	3.0	2.7	5.9	1HW 403	1HW 503	FULL BORE
	3/4"	20	W3	117.5	4.63	N.A.	N.A.	17.5	0.69	85	3.3	3.4	7.5	1HW 404	1HW 504	
	1"	25	W3	127	5.00	140	5.50	22.5	0.89	100	3.9	4.9	10.9	1HW 405	1HW 505	
	1-1/2"	40	W3	165	6.50	178	7.00	35	1.38	125	4.9	9.5	20.9	1HW 407	1HW 507	
	2"	50	W3	203	7.99	216	8.49	45	1.77	140	5.5	15.2	33.5	1HW 408	1HW 508	
ASME 300	1/2"	15	W3	152.5	6.00	163.5	6.44	13	0.51	75	3.0	3.4	7.5	3HW 403	3HW 503	
	3/4"	20	W3	178	7.01	190.5	7.51	17.5	0.69	90	3.5	6.1	13.4	3HW 404	3HW 504	
	1"	25	W3	203	7.99	216	8.49	22.5	0.89	100	3.9	7.8	17.2	3HW 405	3HW 505	
	1-1/2"	40	W3	229	9.02	241	9.52	35	1.38	120	4.7	14.3	31.4	3HW 407	3HW 507	
	2"	50	W3	267	10.51	282.5	11.13	45	1.77	150	5.9	20.0	44.0	3HW 408	3HW 508	
ASME 600	1/2"	15	W3	165	6.50	163.5	6.44	13	0.51	75	3.0	3.6	8.0	6HW 403	6HW 503	
	3/4"	20	W3	191	7.52	190.5	7.52	17.5	0.69	90	3.5	6.2	13.6	6HW 404	6HW 504	
	1"	25	W3	216	8.50	216	8.50	22.5	0.89	100	3.9	8.1	17.8	6HW 405	6HW 505	
	1-1/2"	40	W3	241	9.49	241	9.49	35	1.38	120	4.7	15.2	33.5	6HW 407	6HW 507	
	2"	50	W3	292	11.50	295	11.62	45	1.77	150	5.9	21.9	48.2	6HW 408	6HW 508	
ASME 1500	1/2"	15	W3	216	8.50	216	8.50	12	0.47	105	4.1	7.1	15.7	15HWF 403	15HWF 503	
	3/4"	20	W3	229	9.02	229	9.02	14.5	0.57	125	4.9	10.6	23.5	15HWF 404	15HWF 504	
	1"	25	W3	254	10.00	254	10.00	19	0.75	135	5.3	13.8	30.4	15HWF 405	15HWF 505	
	1-1/2"	40	W3	305	12.01	305	12.01	31	1.22	155	6.1	25.2	55.5	15HWF 407	15HWF 507	
	2"	50	W3	368	14.49	371.5	14.61	38	1.50	195	7.7	47.5	104.7	15HWF 408	15HWF 508	
ASME 2500	1/2"	15	W3	264	10.39	264	10.39	11	0.43	128	5.0	13.6	29.9	25HWF 403	25HWF 503	
	3/4"	20	W3	273	10.75	273	10.75	14.5	0.57	130	5.1	15.2	33.5	25HWF 404	25HWF 504	
	1"	25	W3	308	12.13	308	12.13	19	0.75	152	6.0	25.0	55.1	25HWF 405	25HWF 505	
	1-1/2"	40	W3	384	15.12	387	15.24	28	1.10	188	7.4	51.3	113.1	25HWF 407	25HWF 507	
	2"	50	W3	451	17.76	454	17.88	38	1.50	190	7.5	53.2	117.3	25HWF 408	25HWF 508	

B/E reserves the right to change designs, dimensions or specifications without notice.

PRODUCT FEATURES:

- Outside Screw and Yoke (OS&Y).
- Self aligning two piece packing gland.
- Integral backseat.
- Integral body flanges.
- Bonnet Extension.

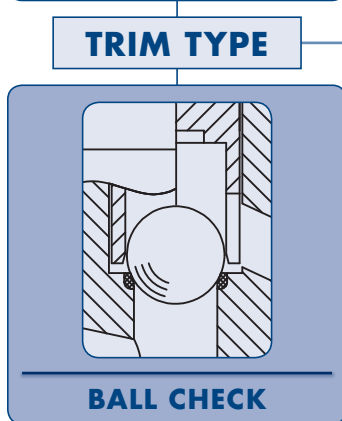
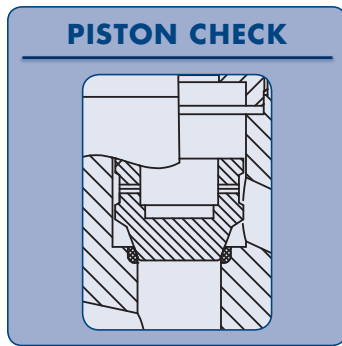

TRIM TYPE

DESIGN TYPE W3 FULL PENETRATION WELD BODY-BONNET CONNECTION

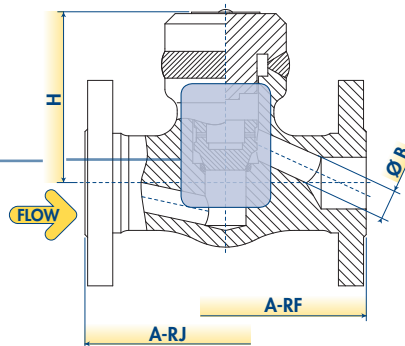

PISTON & BALL CHECK VALVES

AVAILABLE OPTIONS FOR PISTON & BALL CHECK VALVES OTHER VALVE OPTIONS OR CUSTOMISED VERSIONS ARE AVAILABLE ON REQUEST, CONTACT BFE FOR SPECIAL REQUIREMENTS.

■ SPRING ASSISTED CHECK VALVES

SPRING ASSISTED PISTON CHECK VALVE

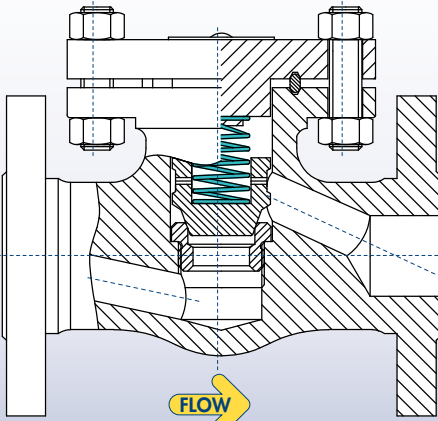

SPRING ASSISTED BALL CHECK VALVE

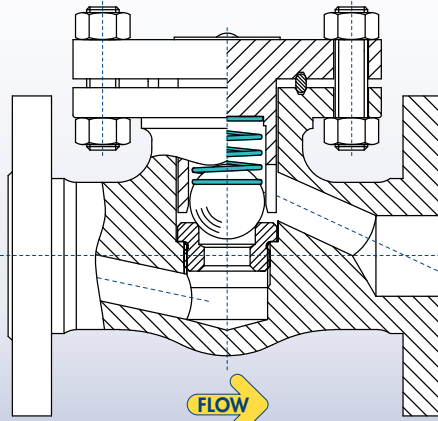

Standard valves have no spring and depend on the weight of the disc to start closure. These are called "horizontal check valves", as they will only function properly when installed in a horizontal line. Spring loaded check valves may be installed in any position, both in horizontal and vertical piping applications. The spring helps reduce noise, minimize the effect of pulsating flow and "water hammer" line shock and assists the closure member in seating faster.

■ SPECIAL END FINISH

The choice of end connections for connecting a valve to its associated pipe is performed by customers. Common end finish stated in the catalogue are socket, threaded, flanged (RF or RJ) and butt-weld ends. BFE is basically able to perform any end finish as per customer request, special end finish. Other end finish as follows: hub, compact flange, any ASME B16.5 end finish other than RF and RJ, etc.

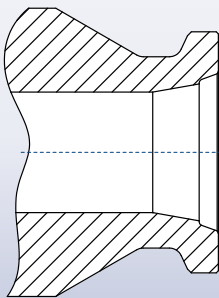

■ DISC AND TRIM TYPE FOR PISTON CHECK VALVES

BFE standard plug is the has a quick opening characteristic, this plug provides maximum flow with minimum pressure drop and is ideal when large flows are required just after opening. All BFE standard plugs require a flow direction FTO type. BFE trim variations can offer maximum versatility in flow control application within the capability of piston check valve design.

SOFT SEATED PLUG

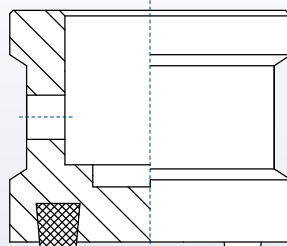

Soft seated trim provides improved seat tightness at low differential pressures. This design feature includes a plastic sealing member on the valve closure element to supplement the basic metal-to-metal seating function. The design and material selection for these sealing members are based on customer pressure, temperature and compatibility with the line fluid.

FLAT SEATED TRIM

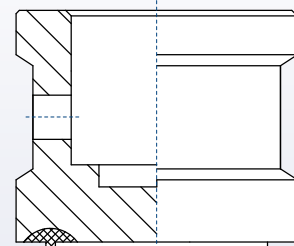

Metal to metal flat seated trim provides improved seat tightness with air/gas service. This design feature is required when additional or special test are required (e.g. API 598 air test or high pressure gas test).

■ CUSTOMIZED CRACKING PRESSURE

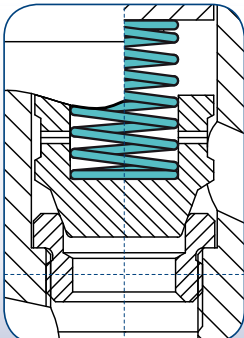

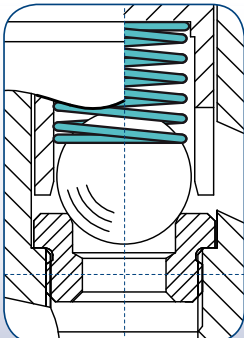

An important concept in check valves is the cracking pressure which is the minimum upstream pressure at which the valve will operate. Static cracking pressure is the minimum pressure at which fluid is by-passed through the valve at the rate of 0.1cc per minute during conditions of increasing pressure supplied by means of a hand pump. Valve cracking pressure can be customized to meet unique performance requirements through the modification of the trim design (closure member geometry, spring force and materials).

PISTON & BALL CHECK VALVES

AVAILABLE OPTIONS FOR PISTON & BALL CHECK VALVES OTHER VALVE OPTIONS OR CUSTOMISED VERSIONS ARE AVAILABLE ON REQUEST, CONTACT BFE FOR SPECIAL REQUIREMENTS.

IN-LINE VERTICAL CHECK VALVES

In-line check valves prevent reverse flow with disc movement that is parallel with the flow. With this design, the disc is always in the flow path. Closure member can be spring-loaded to assist in seating. The in-line check valve disc has very short disc travel and responds very quickly to flow stoppage or reversal, thus minimizing the potential for water hammer. The in-line check valve produces the most pressure drop when compared to other check valves of the same size.

IN-LINE BALL CHECK VALVE

VALVE SHOWN IN OPEN POSITION

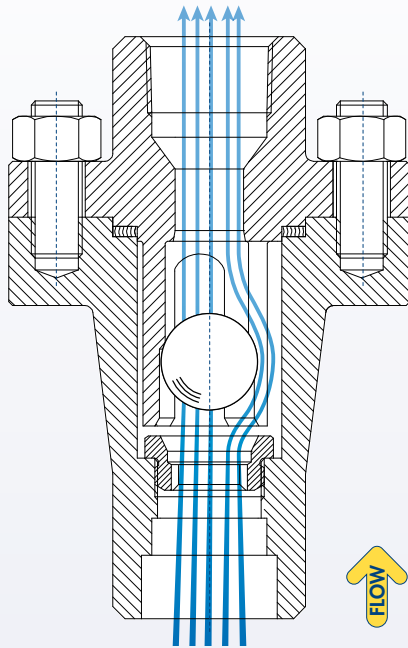

SPRING ASSISTED IN-LINE BALL CHECK VALVE

VALVE SHOWN IN CLOSED POSITION

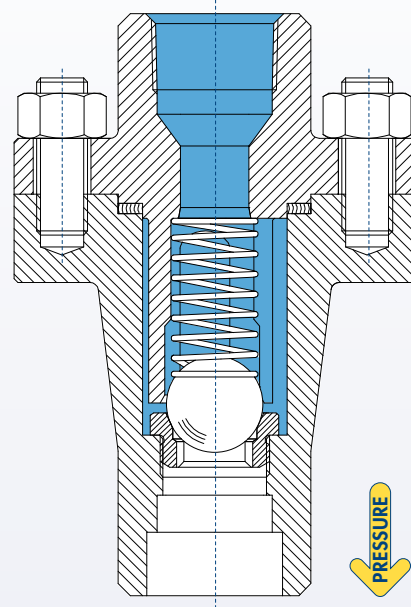

IN-LINE PISTON CHECK VALVE

VALVE SHOWN IN OPEN POSITION

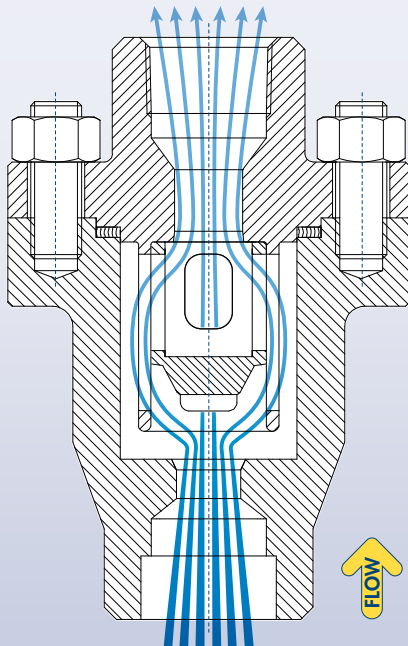

SPRING ASSISTED IN-LINE PISTON CHECK VALVE

VALVE SHOWN IN CLOSED POSITION

