

CBB-Series Scotch-Yoke Pneumatic Actuators

Improved Design - Compact, Lightweight To Suit All Applications And Environment



BETTIS™



Approved Emerson-Bettis distributor, service facility and stockist.
www.globalsupplyline.com.au sales@globalsupplyline.com.au
Full stock list [click here](#)

EMERSON™



Emerson is the global leader in providing safe, reliable, rugged actuators and automation solutions for the oil & gas, process, nuclear and other industries.

Improved design with many beneficial features for various industrial applications and conditions.

Improved torque shaft seal design is well suited for most environments.

Protects the environment with a leak protection, separate weather and pressure seal design that provides reliable dual redundancy in the actuator.

Improved travel stop design.

Enhanced performance and reliability suited for tough environments.

Easy field upgrade for high temperature trim with ductile iron piston as standard.

Design and Construction

Emerson, a leading pioneer in the valve automation and control industry for more than 55-years, has developed numerous innovations that have become today's industry standards. With continued focus on ingenuity, reliability, quality and product safety, our entire product offering is considered to be the global standard for automating valves in the oil & gas, power generation, pulp and paper, petrochemical, chemical, wastewater, and numerous other process industries. Performance has been the main differentiator. Emerson is recognized for effectiveness and reliability in some of the world's most difficult operating environments.

CBB-Series actuator represents the latest generation in pneumatic scotch yoke actuators from Emerson. The CBB draws from the best features of earlier versions – CB and CBA. Incorporating cutting edge features provides the CBB with a proven, rugged design that is dependable and reliable in the field. Because it has the same envelope dimensions and mounting interfaces as previous CB versions, the CBB allows for mounting interchangeability.

Compact, lightweight and ideally suited for automating ball, butterfly and non-lubricated plug valves, or any quarter-turn (90 degree) rotating mechanism, the CBB Series is also economical and low maintenance. Available in double-acting and spring-return models and are independently certified to IEC 60529 IP66 and IP67M for water ingress protection.

Emerson's quarter-turn rotary actuators utilize a ductile iron housing, advanced water ingress prevention design, and a two component polyurethane paint finish to ensure years of reliable performance in harsh environmental conditions. In addition to these standard features, CBB-Series actuators are available with optional accessories to meet the demanding requirements in valve automation.

CBB Series Application And Features

- For use with automating ball, butterfly and non-lubricated plug valves, or any quarter-turn (90 degree) rotating mechanism.
- PED 97/23/EC compliant to meet the stringent requirements of pressure retaining vessels.
- Compact, lightweight, and economical scotch-yoke design providing optimum torque curves for quarter-turn operation.
- Choice of 29 sizes with guaranteed minimum torque outputs up to 11,515 lb-in (1,301 Nm) for double -acting and 4,269 lb-in (482 Nm) spring-return configuration.
- Standard dual valve mounting interface provides flexibility for installation in a fail-open or fail-close application without the need of actuator disassembly. Installation is possible in any position, parallel or at right angles to the flow line, in the vertical or horizontal plane.
- Ductile iron housing and piston provide more strength per pound, increased durability and corrosion resistance.
- Increased actuator efficiency and corrosion resistance are possible with a Xylan fluoropolymer coating on the interior of the power cylinder. The permanently-bonded coating is highly resistant to abrasion, thermal shock and provides excellent lubricity and low friction properties.
- Close Loop Instrument System for actuators **should always be used** for the following applications: high humidity, salt air, corrosive dust, inks and dyes, and wash downs. The closed loop system routes the operating media being exhausted from the power side of the cylinder to the vented side of the cylinder. Maximum pressure on the vented side of the power cylinder is to be 5 to 8 psig.

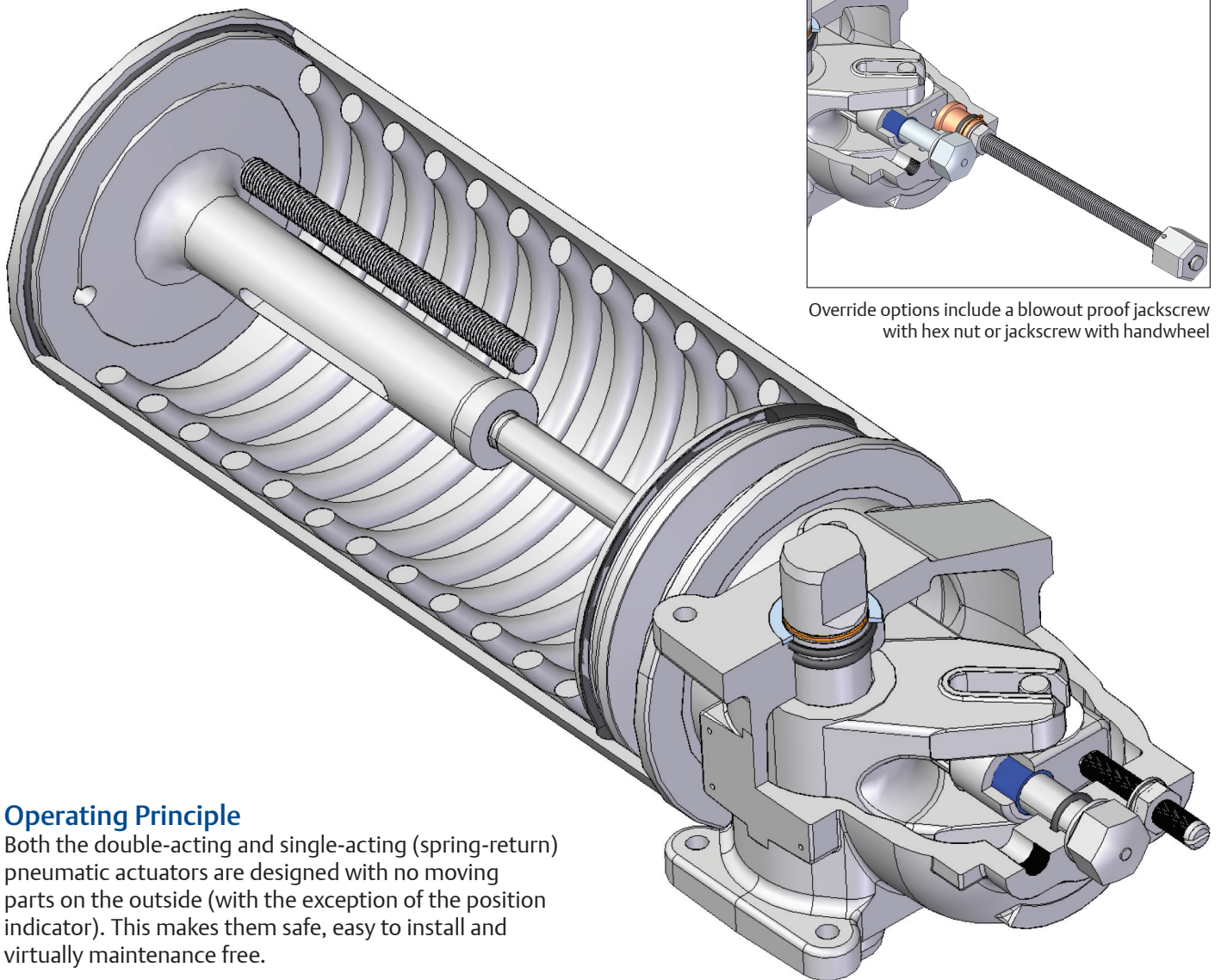

Override options include a blowout proof jackscrew with hex nut or jackscrew with handwheel

Operating Principle

Both the double-acting and single-acting (spring-return) pneumatic actuators are designed with no moving parts on the outside (with the exception of the position indicator). This makes them safe, easy to install and virtually maintenance free.

Environmental Protection

Actuator reliability is crucial for the safety of a plant's automation process and personnel. The CBB-Series is independently certified to IEC 60529 IP66 and IP67M water ingress protection to prevent corrosion within the actuator. To help achieve this rating, CBB-Series incorporates a proven design for preventing water ingress on the torque shaft by using a separate pressure seal and weather resistance between the torque shaft and housing body.

Extreme temperatures require different solutions to maintain peak operational integrity and reliability. The CBB-Series is available in three different temperature trims:

- Standard trim is suitable for -20°F to +200°F (-29°C to +93°C)
- Optional high temperature trim +350°F (-18°C to +177°C)
- Cold temperature trim -40°F to +150°F (-40°C to +66°C)

Multiple Spring Packages

Spring-return, single-acting actuators are used mainly as a fail-safe method for closing or opening the valve. Their ability to automatically return the valve to its fail safe position upon air failure provides the vital link for ultimate system safety and shut down. CBB-Series spring-return actuators are available in 4-four-spring configurations fitting wide range of torque requirements under different supply pressures and operating parameters. Each of the carbon steel springs are protected by Tactyl 50, a pliable self-healing coating, for extending the CBB's life cycle.

Flexible Configurations

Requirements for process automation sometimes vary within a facility. To meet industry demands for product standardization with adaptability, Emerson offers many options for the CBB-Series:

- Override modules to reposition a valve in the event of a power loss can be supplied with a jackscrew and hex nut adaptor or a jackscrew with handwheel
- Optional temperature trims to meet harsh temperature extremes
- Extended and adjustable travel stops for each direction of travel
- Various spring configurations to meet torque and pressure requirements are some of most common options chosen

Travel Stops

Instrumentation for valve automation requires repeatable positioning and position indication. CBB-Series actuators include bidirectional travel stops as an integral part of the actuator. Travel stops are adjustable from 80° to 100° of total valve travel. This feature, with its unmatched travel range, assists in prolonging valve seat integrity. Applications requiring greater adjustment of valve travel can be supplied with the optional extended travel stops for full valve stroke travel adjustment.

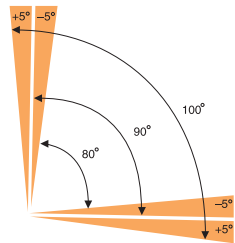

Long Life Span

The rugged and dependable construction of the CBB actuator is backed with Emerson's industry leading five year warranty on materials and workmanship. With the use of superior design and materials throughout the construction, CBB spring-return actuators and double action actuators have a long cycle life when properly maintained and sized.

Safety Integrity Level (SIL)

CBB actuators are well suited for demanding SIL applications. These actuators have a Failure Modes and Effects Diagnostics Analysis (FMECA) capability with reporting performed through Exida.com™ for SIL suitability. When a Fisher, TÜV-certified FIELDVUE® controller is added to the CBB, it is capable of partial stroke testing and providing continuous monitoring of supply pressure, valve position and pressure values to verify proper working condition. The CBB then becomes an integral component in controlling the final control element in SIL 1, 2 or 3 applications.

Product Offering

Emerson's Bettis product line is not limited in its technology offering for selecting the best configuration for use in automated service. With a wide range of hydraulic and pneumatic technologies for meeting critical customer requirements including:

- Scotch-Yoke
- Linear
- Rack & Pinion
- Direct Gas
- Gas Hydraulic
- Electric
- Self-Contained
- Multiport Flow Selector
- Controls
- Accessories
- Trims – include N(Nuclear) trim



For more detailed technical information go to our online documentation at www.bettis.com/technical-data
Document number [DOC.DSB.CBB.A4]

Actuator / Accessory Interfaces

Standards and Certifications

CBB-Series pneumatic actuators are manufactured to meet the following worldwide quality and safety standards:



CE



ISO-9001



ABS

PED/97/23/EC –
Pressure
Equipment
Directive



Bettis CBB with Topworx Positioner



Bettis CBB with Wireless Transmitter

Valve Automated Packages

Emerson offers a complete valve operating system as a solution for final valve control.

Emerson's capability to combine the CBB actuator and controls with the selected valve into a single system at various international Actuation Technologies World Automation Configuration Centers (WACC) – makes them perfect for large international projects.

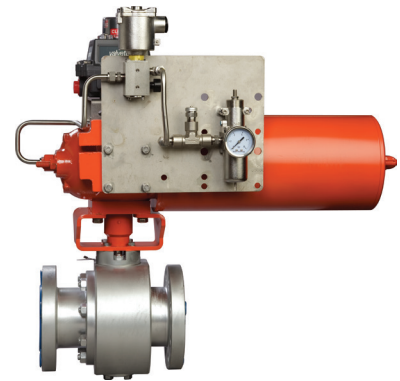

Supporting our valve automation solutions, Emerson has pre-engineered and documented a series of commonly required and approved control system that will reduce lead times, simplify purchasing, installation and start-up.

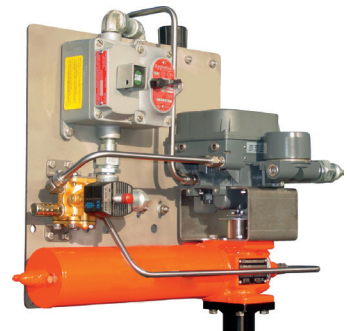

Please consult factory for additional information.

Other Emerson controls and accessories:

Fisher™

- Digital Valve Controllers
- Positioners
- Regulators

TopWorx™

- Switch Boxes
- Wireless Position Monitoring

ASCO Numatics™

- Solenoid Valves

This product is only intended for use in large-scale fixed installations excluded from the scope of Directive 2011/65/EU on the restriction of the use of certain hazardous substances in electrical and electronic equipment (RoHS 2).

World Area Configuration Centers (WACC) offer sales support, service, inventory and commissioning to our global customers. Choose the WACC or sales office nearest you:

NORTH & SOUTH AMERICA

19200 Northwest Freeway
Houston TX 77065
USA
T +1 281 477 4100

Av. Hollingsworth
325 Iporanga Sorocaba
SP 18087-105
Brazil
T +55 15 3413 8888

ASIA PACIFIC

No. 9 Gul Road
#01-02 Singapore 629361
T +65 6777 8211

No. 1 Lai Yuan Road
Wuqing Development Area
Tianjin 301700
P. R. China
T +86 22 8212 3300

MIDDLE EAST & AFRICA

P. O. Box 17033
Jebel Ali Free Zone
Dubai
T +971 4 811 8100

P. O. Box 10305
Jubail 31961
Saudi Arabia
T +966 3 340 8650

24 Angus Crescent
Longmeadow Business Estate East
P.O. Box 6908 Greenstone
1616 Modderfontein Extension 5
South Africa
T +27 11 451 3700

EUROPE

Holland Fasor 6
Székesfehérvár 8000
Hungary
T +36 22 53 09 50

Strada Biffi 165
29017 Fiorenzuola d'Arda (PC)
Italy
T +39 0523 944 411

For complete list of sales and manufacturing sites, please visit www.emerson.com/actuationtechnologieslocations or contact us at info.actuationtechnologies@emerson.com

©2018 Emerson. All rights reserved.

The Emerson logo is a trademark and service mark of Emerson Electric Co. Bettis™ is a mark of the Emerson family of companies. All other marks are property of their respective owners.

Torque - Pneumatic Double-Acting Actuator

Actuator Model	Metric Unit	Stroke Direction	Operating Pressure, barg																	MinOP barg	MOP barg
			2.7	3	3.2	3.5	3.7	4	4.2	4.5	4.7	5	5.5	6	6.5	7	7.5	8	8.5		
			Air Torque Output, Nm																		
CBB315	Start	Outboard	74	84	90	99	106	115	121	131	137	146	162	177	193	209	224	240	256	2.8	8.3
	Min		41	46	50	55	58	63	66	71	75	80	88	96	105	113	122	130	138		
	End		78	87	94	103	109	119	125	134	141	150	166	181	197	213	229	244	260		
CBB315	Start	Inboard	74	83	90	99	105	115	121	130	136	146	161	177	192	208	224	239	255	2.8	8.3
	Min		41	46	50	55	58	63	66	71	75	80	88	96	105	113	122	130	138		
	End		78	88	94	103	110	119	125	135	141	150	166	182	198	213	229	245	261		
CBB420	Start	Outboard	166	186	199	220	233	253	267	287	300	321	354	388	421	455	489	522	556	2.8	8.3
	Min		94	105	112	123	130	141	149	160	167	178	197	215	233	252	270	289	307		
	End		171	191	204	224	238	258	271	291	305	325	358	392	426	459	493	526	560		
CBB420	Start	Inboard	165	185	198	218	231	251	265	285	298	318	351	385	418	451	485	518	552	2.8	8.3
	Min		94	105	112	123	130	141	149	160	167	178	197	215	233	252	270	289	307		
	End		172	192	206	226	239	260	273	294	307	327	361	395	429	463	496	530	564		
CBB520	Start	Outboard	266	297	319	351	372	404	425	457	478	510								2.8	4.8
	Min		149	166	178	195	207	224	236	253	265	282									
	End		272	304	325	357	378	410	431	463	484	516									
CBB520	Start	Inboard	264	295	316	348	369	401	422	454	475	506								2.8	4.8
	Min		149	166	178	195	207	224	236	253	265	282									
	End		274	306	328	360	381	413	434	466	488	520									
CBB525	Start	Outboard	338	379	406	447	474	514	542	582	609	650	718	786	854	922	990	1,058	1,125	2.8	8.3
	Min		182	204	218	239	253	275	289	310	324	346	381	417	453	488	524	559	595		
	End		349	390	417	458	485	526	554	595	622	663	731	799	867	936	1,004	1,072	1,140		
CBB525	Start	Inboard	338	379	406	446	474	514	541	582	609	650	718	786	854	922	990	1,057	1,125	2.8	8.3
	Min		182	204	218	239	253	275	289	310	324	346	381	417	453	488	524	559	595		
	End		349	390	417	458	485	526	554	594	622	663	731	799	867	935	1,004	1,072	1,140		
CBB725	Start	Outboard	690	771	825	906	960	1,041	1,095	1,176	1,230	1,311	1,446							2.8	5.5
	Min		368	411	439	481	509	552	580	623	651	693	764								
	End		706	787	841	922	976	1,058	1,112	1,193	1,247	1,329	1,464								
CBB725	Start	Inboard	690	771	825	906	960	1,041	1,095	1,176	1,230	1,311	1,446							2.8	5.5
	Min		368	411	439	481	509	552	580	623	651	693	764								
	End		705	787	841	922	976	1,057	1,112	1,193	1,247	1,328	1,464								

Torque - Pneumatic Spring-Return Actuator

Actuator Model	Spring Torque Start/Min./End (Nm)	Operating Pressure, (barg)																MinOP (barg)	Torque @ MinOP (Nm)	MOP (barg)	Torque @ MOP (Nm)				
		2.5	3	3.5	3.8	4	4.5	5	5.5	6	7	7.5	8.5	9	10	10.5	11					11.5			
		Pressure Torque Output: Start/Min./End (Nm)																							
CBB315-SR40	Start	35	30	43	57	65	70	84	98	111	125	152	166	193	206	233	247	Exceeds MOP	2.4	27	10.7	252			
	Min.	15	12	19	26	31	34	41	48	55	62	76	83	97	104	118	125						11	128	
	End	21	15	28	42	50	55	69	82	95	109	136	149	176	189	216	230						12	235	
CBB315-SR60	Start	57			Please consult factory	51	56	70	84	97	111	138	151	179	192	219	233	Exceeds MOP	3.6	46	10.5	233			
	Min.	25				21	24	31	38	45	52	66	73	87	94	109	116						18	116	
	End	35				27	33	46	59	73	86	113	126	153	167	194	207						22	207	
CBB315-SR80	Start	80						Please consult factory	69	83	97	124	137	164	178	205	Exceeds MOP	4.8	64	10.3	213				
	Min.	34							28	35	42	56	63	78	85	99						25	103		
	End	49							37	50	64	90	104	131	144	171						31	179		
CBB315-SR100	Start	103							Please consult factory	83	110	123	151	164	191	205	219	Exceeds MOP	6.0	83	11.3	227			
	Min.	43						32		46	54	68	75	89	96	103	32						108		
	End	63						41		68	81	108	121	148	162	175	41						183		
CBB415-SR40	Start	72	59	84	108	123	133	158	182	207	231	Exceeds MOP						2.5	59	6.9	275				
	Min.	30	23	36	49	56	62	74	87	100	113												23	136	
	End	41	28	52	76	91	100	124	149	173	197												28	241	
CBB415-SR60	Start	110			Please consult factory	96	106	131	155	180	204	253	278	Exceeds MOP					3.7	91	7.7	288			
	Min.	47				38	44	57	70	82	95	121	134											36	139
	End	68				52	61	85	110	134	158	207	231											47	241
CBB415-SR80	Start	149						Please consult factory	132	156	181	230	255	Exceeds MOP					4.8	122	8.1	284			
	Min.	63							52	65	78	104	117											47	132
	End	92							71	95	119	168	192											61	221
CBB415-SR100	Start	204							Please consult factory			224	248	Exceeds MOP					6.4	194	7.9	268			
	Min.	77								86	99													69	109
	End	98										112	136											83	156

Note: All Published Torques are Guaranteed Minimum Values. Units are Metric

Torque - Pneumatic Spring-Return Actuator

Actuator Model	Spring Torque Start/Min./End (Nm)	Operating Pressure, (barg)																MinOP (barg)	Torque @ MinOP (Nm)	MOP (barg)	Torque @ MOP (Nm)	
		2.5	3	3.5	3.8	4	4.5	5	5.5	6	7	7.5	8.5	9	10	10.5	11					11.5
		Pressure Torque Output: Start/Min./End (Nm)																				
CBB420-SR40	Start	86	Please consult factory	112	143	161	173	204	235	266	296	358	389	450	481	543	573	Exceeds MOP	2.6	87	10.8	592
	Min	34		44	60	70	76	92	107	123	138	169	185	216	232	263	278			31		288
	End	44		60	89	106	118	146	175	204	233	290	319	377	405	463	492			37		509
CBB420-SR60	Start	137	Please consult factory	130	143	173	204	235	266	327	358	419	450	512	543	Exceeds MOP	3.8	130	10.8	561		
	Min	56		46	53	69	84	100	116	147	163	194	209	241	256			46		266		
	End	75		54	66	95	123	152	181	239	267	325	354	411	440			54		457		
CBB420-SR80	Start	187	Please consult factory	178	209	239	301	332	393	424	486	516	547	Exceeds MOP	5.0	178	11.1	553				
	Min	75		62	79	95	126	142	173	189	220	236	251			62		254				
	End	102		73	102	131	189	217	275	304	361	390	419			73		425				
CBB420-SR100	Start	243	Please consult factory	274	304	366	397	458	489	520	Exceeds MOP	6.3	231	11.4	545							
	Min	97		102	118	150	166	197	213	228			79		241							
	End	129		132	161	219	248	305	334	363			92		386							
CBB520-SR40	Start	143	Please consult factory	184	232	261	281	329	377	426	474	571	619	Exceeds MOP	2.6	145	7.6	629				
	Min	55		71	96	111	121	146	170	195	219	269	293			51		298				
	End	68		94	139	167	185	230	276	322	367	458	504			57		513				
CBB520-SR60	Start	217	Please consult factory	204	224	272	320	368	417	513	562	Exceeds MOP	3.7	195	8.0	610						
	Min	90		75	85	110	135	160	184	233	258			69		283						
	End	125		92	110	156	201	247	292	383	429			83		474						
CBB520-SR80	Start	298	Please consult factory	280	328	377	473	522	Exceeds MOP	5.0	280	8.3	599									
	Min	121		100	125	150	200	225			100		264									
	End	165		120	165	211	302	348			120		421									
CBB520-SR100	Start	408	Please consult factory	394	442	539	587	Exceeds MOP	6.7	365	9.1	597										
	Min	170		147	173	223	247			132		252										
	End	245		192	237	328	374			164		383										

Note: All Published Torques are Guaranteed Minimum Values. Units are Metric

Torque - Pneumatic Spring-Return Actuator

Actuator Model	Spring Torque Start/Min./End (Nm)	Operating Pressure, (barg)																MinOP (barg)	Torque @ MinOP (Nm)	MOP (barg)	Torque @ MOP (Nm)			
		2.5	3	3.5	3.8	4	4.5	5	5.5	6	7	7.5	8.5	9	10	10.5	11					11.5		
		Pressure Torque Output: Start/Min./End (Nm)																						
CBB525-SR40	Start	167	140	198	256	291	314	372	430	488	546	662	720	836	894	1,010	Exceeds MOP		2.4	128	10.1	1,022		
	Min.	71	58	89	120	139	151	182	212	243	273	335	365	426	457	518				52		524		
	End	103	80	139	197	233	256	315	374	433	492	610	669	787	846	964				68		976		
CBB525-SR60	Start	270			Please consult factory	239	262	320	378	436	494	610	668	784	842	958	Exceeds MOP		3.7	227	10.4	1,005		
	Min.	110				96	108	140	171	201	232	293	324	385	416	477				90		502		
	End	155				129	153	212	271	329	388	506	565	683	742	860				117		907		
CBB525-SR80	Start	376						Please consult factory	324	382	440	556	614	730	788	904	962	1,020	Exceeds MOP	4.9	312	11.0	1,020	
	Min.	151							126	157	188	250	281	343	373	435	465	496			119		496	
	End	210							164	223	282	400	459	577	636	754	813	872			153		872	
CBB525-SR100	Start	473									Please consult factory	497	555	671	729	846	904	962	Exceeds MOP	6.1	393	11.2	985	
	Min.	191										208	239	301	332	393	424	455			151		467	
	End	269										302	361	479	538	656	715	774			196		798	
CBB725-SR40	Start	363	298	413	528	598	644	759	874	990	1,105	1,336	Exceeds MOP						2.5	298	7.0	1,336		
	Min.	151	118	180	241	278	302	363	424	485	546	667								118		667		
	End	215	156	273	390	460	507	624	741	858	975	1,209								156		1,209		
CBB725-SR60	Start	574			Please consult factory	483	530	645	760	876	991	1,222	1,337	Exceeds MOP						3.8	483	7.9	1,430	
	Min.	233				188	214	276	337	398	459	581	642								188		691	
	End	330				249	296	413	530	647	764	998	1,115								249		1,209	
CBB725-SR80	Start	771						Please consult factory	649	764	880	1,111	1,226	1,457	Exceeds MOP						5.0	649	8.5	1,457
	Min.	312							251	314	376	499	560	682						251		682		
	End	441							332	449	566	800	917	1,151						332		1,151		
CBB725-SR100	Start	1,016									Please consult factory	1,029	1,144	1,375	Exceeds MOP						6.5	913	8.5	1,375
	Min.	391										406	468	592						343		592		
	End	524										555	672	906						438		906		

Note: All Published Torques are Guaranteed Minimum Values. Units are Metric

Torque - Pneumatic

Double-Acting Actuator

Actuator Model	Metric Unit	Stroke Direction	Operating Pressure,barg																MinOP barg	MOP barg			
			2.7	3	3.2	3.5	3.7	4	4.2	4.5	4.7	5	5.5	6	6.5	7	7.5	8			8.5		
			Air Torque Output,Nm																				
CBA730	Start	Outboard	835	933	999	1,097	1,163	1,261	1,327	1,425	1,490	1,589	1,752	1,916	2,080	2,244	2,408					2.8	7.2
	Min		446	498	532	584	618	670	704	755	790	841	927	1,013	1,099	1,185	1,271						
	End		854	953	1,018	1,117	1,183	1,281	1,347	1,445	1,511	1,610	1,774	1,938	2,102	2,267	2,431						
CBA730	Start	Inboard	835	933	999	1,097	1,162	1,260	1,326	1,424	1,490	1,588	1,752	1,915	2,079	2,243	2,407					2.8	7.2
	Min		446	498	532	584	618	670	704	755	790	841	927	1,013	1,099	1,185	1,271						
	End		854	953	1,019	1,117	1,183	1,282	1,347	1,446	1,512	1,610	1,775	1,939	2,103	2,268	2,432						
CBA830	Start	Outboard	1,107	1,236	1,322	1,451	1,537	1,666	1,752	1,881	1,967	2,096	2,312	2,527								2.8	5.5
	Min		590	657	702	770	815	883	928	995	1,041	1,108	1,221	1,334									
	End		1,128	1,257	1,344	1,473	1,559	1,689	1,775	1,904	1,991	2,120	2,336	2,552									
CBA830	Start	Inboard	1,106	1,235	1,321	1,450	1,536	1,665	1,751	1,880	1,966	2,096	2,311	2,526								2.8	5.5
	Min		590	657	702	770	815	883	928	995	1,041	1,108	1,221	1,334									
	End		1,128	1,258	1,344	1,474	1,560	1,689	1,776	1,905	1,992	2,121	2,337	2,553									
CBA930	Start	Outboard	1,415	1,579	1,689	1,853	1,962	2,126	2,236	2,400	2,509											2.8	4.5
	Min		752	838	895	981	1,039	1,125	1,182	1,268	1,325												
	End		1,439	1,603	1,713	1,877	1,987	2,151	2,261	2,426	2,535												
CBA930	Start	Inboard	1,414	1,578	1,688	1,852	1,961	2,125	2,235	2,399	2,508											2.8	4.5
	Min		752	838	895	981	1,039	1,125	1,182	1,268	1,325												
	End		1,439	1,604	1,714	1,878	1,988	2,152	2,262	2,427	2,536												
CBA1030	Start	Outboard	1,883	2,100	2,245	2,462	2,606															2.8	3.4
	Min		998	1,112	1,188	1,301	1,377																
	End		1,910	2,127	2,272	2,490	2,635																
CBA1030	Start	Inboard	1,882	2,099	2,244	2,461	2,605															2.8	3.4
	Min		998	1,112	1,188	1,301	1,377																
	End		1,911	2,128	2,273	2,491	2,636																

Torque - Pneumatic Spring-Return Actuator

Actuator Model	Metric Unit	Spring Torque Nm	Operating Pressure, barg																	MinOP barg	MOP barg			
			2	2.5	3	3.5	4	4.5	5	5.5	6	6.5	7	7.5	8	8.5	9	9.5	10			10.5	11	11.5
			Air Torque Output, Nm																					
CBA730-SR40	Start	484																					2.4	9.3
	Min	198	409	564	719	874	1,029	1,184	1,338	1,493	1,648	1,803	1,958	2,113	2,268	2,423	2,578							
CBA830-SR40	End	275	158	242	324	406	488	569	651	732	813	895	976	1,057	1,139	1,220	1,301						2.4	7.2
	Start	643	549	752	956	1,159	1,363	1,566	1,770	1,973	2,177	2,380	2,584											
CBA930-SR40	Min	262	213	322	430	538	645	752	859	966	1,073	1,180	1,286										2.4	5.9
	End	472	356	615	874	1,134	1,393	1,653	1,912	2,171														
CBA1030-SR40	Start	827	708	966	1,225	1,483	1,742	2,001	2,259	2,518													2.4	4.8
	Min	448	367	551	732	913	1,093	1,273																
CBA730-SR60	End	623	473	816	1,159	1,501	1,844	2,187															3.6	9.7
	Start	764			577	732	887	1,042	1,197	1,352	1,507	1,662	1,817	1,972	2,127	2,282	2,437	2,592						
CBA830-SR60	Min	304			204	289	372	455	537	619	701	782	864	945	1,027	1,108	1,190	1,271					3.7	7.6
	End	416			233	388	544	699	855	1,010	1,166	1,321	1,477	1,632	1,788	1,943	2,099	2,254						
CBA930-SR60	Start	1,044			808	1,011	1,215	1,418	1,622	1,825	2,029	2,232	2,436	2,640									3.8	6.2
	Min	397			267	382	492	601	709	817	924	1,032	1,139	1,246										
CBA1030-SR60	End	515			282	486	690	895	1,099	1,303	1,507	1,711	1,916	2,120									3.8	5.2
	Start	1,362				1,331	1,590	1,849	2,107	2,366	2,625													
CBA730-SR80	Min	501				487	628	767	905	1,042	1,179												5.0	10.0
	End	624				598	857	1,117	1,376	1,636	1,895													
CBA830-SR80	Start	1,830				1,807	2,149	2,491	2,833														5.0	7.9
	Min	659				649	837	1,021	1,204															
CBA930-SR80	End	800				783	1,126	1,468	1,811														5.0	6.6
	Start	1,079						940	1,095	1,249	1,404	1,559	1,714	1,869	2,024	2,179	2,334	2,489						
CBA1030-SR80	Min	405						331	417	501	584	667	749	831	913	995	1,077	1,158					4.9	5.5
	End	519						385	540	696	851	1,007	1,162	1,318	1,473	1,629	1,784	1,940						
CBA730-SR100	Start	1,433						1,258	1,461	1,665	1,868	2,072	2,276	2,479									6.2	10.3
	Min	533						439	552	662	771	880	988	1,096										
CBA830-SR100	End	675						505	709	914	1,118	1,322	1,526	1,730									6.3	8.3
	Start	1,833						1,617	1,875	2,134	2,393	2,652												
CBA930-SR100	Min	678						562	705	846	985	1,123											6.3	7.2
	End	856						646	905	1,165	1,424	1,683												
CBA730-SR100	Start	2,388						2,090	2,432	2,774													6.2	10.3
	Min	911						752	940	1,124														
CBA830-SR100	End	1,201						911	1,253	1,596													6.3	8.3
	Start	1,354								1,111	1,266	1,421	1,576	1,731	1,886	2,041	2,196	2,351	2,506					
CBA930-SR100	Min	510								378	465	550	633	717	799	882	964	1,046	1,128				6.3	7.2
	End	658								420	575	731	886	1,042	1,197	1,353	1,509	1,664	1,820					
CBA730-SR100	Start	1,835								1,516	1,720	1,923	2,127	2,331	2,534								6.3	8.3
	Min	667								491	607	720	831	941	1,050									
CBA830-SR100	End	824								512	716	921	1,125	1,329	1,533								6.3	7.2
	Start	2,306								1,898	2,156	2,415	2,674											
CBA930-SR100	Min	857								633	779	921	1,062										6.3	7.2
	End	1,092								691	951	1,210	1,469											

Bettis CBB-Series

Pneumatic Double-Acting and Spring-Return Actuator Torque Chart Metric

BETTIS™



Torque - Pneumatic Double-Acting Actuator

Actuator Model	Stroke Direction Start/Min./End		Operating Pressure, (barg)																MinOP (barg)	Torque @ MinOP (Nm)	MOP (barg)	Torque @ MOP (Nm)	
			2.5	3	3.5	3.8	4	4.5	5	5.2	5.5	6	6.2	6.5	7	7.2	7.5	8					8.2
Pressure Torque Output: Start/Min./End (Nm)																							
CBB315	Outboard	Start	77	92	101	106	121	135	141	150	164	170	179	193	199	208	222	228	2.8	8.3	72	231	
		Min	43	50	55	58	66	73	76	81	89	92	96	104	107	112	119	123			40	124	
		End	83	98	107	113	128	143	149	158	172	178	187	202	208	217	232	238			77	241	
	Inboard	Start	79	94	103	109	123	138	144	153	168	174	182	197	203	212	227	233			73	236	
		Min	43	50	55	58	66	73	76	81	89	92	96	104	107	112	119	123			40	124	
		End	81	96	105	111	125	140	146	154	169	175	184	198	204	213	227	233			75	236	
CBB420	Outboard	Start	172	203	222	234	265	296	309	327	358	371	389	421	433	452	483	495	2.8	8.3	159	501	
		Min	96	113	123	130	147	164	170	180	197	204	214	231	238	248	265	272			89	275	
		End	192	226	246	260	293	327	341	361	395	408	428	462	476	496	530	543			179	550	
	Inboard	Start	185	219	239	252	286	319	332	353	386	399	419	453	466	486	520	533			172	540	
		Min	96	113	123	130	147	164	170	180	197	204	214	231	238	248	265	272			89	275	
		End	178	210	228	241	272	303	316	335	366	379	397	429	441	460	491	504			166	510	
CBB520	Outboard	Start	275	324	353	373	422	Exceeds MOP												2.8	4.8	255	452
		Min	152	179	195	206	232															142	248
		End	304	357	388	410	463															282	495
	Inboard	Start	294	346	378	399	452															273	483
		Min	152	179	195	206	232															142	248
		End	284	333	363	383	432															264	462
CBB525	Outboard	Start	355	419	457	483	546	610	636	674	738	763	801	865	890	929	992	1,018	2.8	8.3	330	1,031	
		Min	190	223	243	256	290	323	336	356	389	403	423	456	469	489	522	536			177	542	
		End	364	427	465	491	554	618	643	681	745	770	809	872	898	936	999	1,025			338	1,037	
	Inboard	Start	352	415	453	478	542	605	630	668	731	756	794	857	883	921	984	1,009			327	1,022	
		Min	190	223	243	256	290	323	336	356	389	403	423	456	469	489	522	536			177	542	
		End	367	431	469	495	559	623	649	687	752	777	816	880	906	944	1,008	1,034			341	1,047	

Note: All Published Torques are Guaranteed Minimum Values. Units are Metric

Torque - Pneumatic

Double-Acting Actuator

Actuator Model	Stroke Direction Start/Min./End		Operating Pressure, (barg)															MinOP (barg)	Torque @ MinOP (Nm)	MOP (barg)	Torque @ MOP (Nm)	
			2.5	3	3.5	3.8	4	4.5	5	5.2	5.5	6	6.2	6.5	7	7.2	7.5					8
Pressure Torque Output: Start/Min./End (Nm)																						
CBB725	Start	Outboard	Please consult factory	724	850	926	977	1,104	1,230	1,281	1,357	Exceeds MOP							2.8	673	5.5	1,357
	Min			383	449	489	515	581	647	674	713		357	713								
	End			733	860	935	986	1,112	1,239	1,289	1,365		683	1,365								
	Start	Inboard		717	843	918	968	1,094	1,219	1,270	1,345		667	1,345								
	Min			383	449	489	515	581	647	674	713		357	713								
	End			740	867	944	995	1,122	1,250	1,301	1,377		689	1,377								
CBA730	Start	Outboard	Please consult factory	884	1,039	1,132	1,194	1,349	1,505	1,567	1,660	1,815	1,877	1,970	2,125	2,187	Exceeds MOP	2.8	822	7.2	2,187	
	Min			470	551	599	632	713	794	826	875	956	988	1,037	1,118	1,150			437		1,150	
	End			899	1,054	1,147	1,209	1,364	1,519	1,581	1,674	1,829	1,891	1,984	2,139	2,201			837		2,201	
	Start	Inboard		879	1,033	1,125	1,187	1,341	1,495	1,557	1,650	1,804	1,866	1,958	2,112	2,174			817		2,174	
	Min			470	551	599	632	713	794	826	875	956	988	1,037	1,118	1,150			437		1,150	
	End			904	1,060	1,154	1,216	1,372	1,528	1,590	1,684	1,840	1,902	1,996	2,152	2,214			842		2,214	
CBA830	Start	Outboard	Please consult factory	1,170	1,374	1,496	1,578	1,782	1,986	2,067	2,189	Exceeds MOP							2.8	1,089	5.5	2,189
	Min			620	726	790	833	939	1,045	1,088	1,152		577	1,152								
	End			1,186	1,390	1,512	1,593	1,797	2,001	2,082	2,204		1,105	2,204								
	Start	Inboard		1,163	1,366	1,487	1,568	1,771	1,974	2,055	2,176		1,082	2,176								
	Min			620	726	790	833	939	1,045	1,088	1,152		577	1,152								
	End			1,194	1,398	1,521	1,603	1,808	2,013	2,095	2,218		1,112	2,218								
CBA930	Start	Outboard	Please consult factory	1,496	1,755	1,910	2,014	2,273	Exceeds MOP										2.8	1,392	4.5	2,273
	Min			790	926	1,007	1,061	1,196		736	1,196											
	End			1,513	1,771	1,927	2,030	2,289		1,409	2,289											
	Start	Inboard		1,487	1,744	1,898	2,001	2,259		1,384	2,259											
	Min			790	926	1,007	1,061	1,196		736	1,196											
	End			1,522	1,782	1,938	2,042	2,303		1,418	2,303											
CBA1030	Start	Outboard	Please consult factory	1,989	Exceeds MOP													2.8	1,852	3.4	2,263	
	Min			1,049		977	1,192															
	End			2,007		1,871	2,281															
	Start	Inboard		1,977		1,841	2,249															
	Min			1,049		977	1,192															
	End			2,020		1,882	2,295															

Note: All Published Torques are Guaranteed Minimum Values. Units are Metric

Torque - Pneumatic Spring-Return Actuator

Actuator Model	Spring Torque Start/Min./End (Nm)	Operating Pressure, (barg)																MinOP (barg)	Torque @ MinOP (Nm)	MOP (barg)	Torque @ MOP (Nm)				
		2.5	3	3.5	3.8	4	4.5	5	5.5	6	7	7.5	8.5	9	10	10.5	11					11.5			
		Pressure Torque Output: Start/Min./End (Nm)																							
CBB315-SR40	Start	35	30	43	57	65	70	84	98	111	125	152	166	193	206	233	247	Exceeds MOP	2.4	27	10.7	252			
	Min.	15	12	19	26	31	34	41	48	55	62	76	83	97	104	118	125						11	128	
	End	21	15	28	42	50	55	69	82	95	109	136	149	176	189	216	230						12	235	
CBB315-SR60	Start	57			Please consult factory	51	56	70	84	97	111	138	151	179	192	219	233	Exceeds MOP	3.6	46	10.5	233			
	Min.	25				21	24	31	38	45	52	66	73	87	94	109	116						18	116	
	End	35				27	33	46	59	73	86	113	126	153	167	194	207						22	207	
CBB315-SR80	Start	80						Please consult factory	69	83	97	124	137	164	178	205	Exceeds MOP	4.8	64	10.3	213				
	Min.	34							28	35	42	56	63	78	85	99						25	103		
	End	49							37	50	64	90	104	131	144	171						31	179		
CBB315-SR100	Start	103							Please consult factory	83	110	123	151	164	191	205	219	Exceeds MOP	6.0	83	11.3	227			
	Min.	43						32		46	54	68	75	89	96	103	32						108		
	End	63						41		68	81	108	121	148	162	175	41						183		
CBB415-SR40	Start	72	59	84	108	123	133	158	182	207	231	Exceeds MOP						2.5	59	6.9	275				
	Min.	30	23	36	49	56	62	74	87	100	113												23	136	
	End	41	28	52	76	91	100	124	149	173	197												28	241	
CBB415-SR60	Start	110			Please consult factory	96	106	131	155	180	204	253	278	Exceeds MOP					3.7	91	7.7	288			
	Min.	47				38	44	57	70	82	95	121	134											36	139
	End	68				52	61	85	110	134	158	207	231											47	241
CBB415-SR80	Start	149						Please consult factory	132	156	181	230	255	Exceeds MOP					4.8	122	8.1	284			
	Min.	63							52	65	78	104	117											47	132
	End	92							71	95	119	168	192											61	221
CBB415-SR100	Start	204							Please consult factory			224	248	Exceeds MOP					6.4	194	7.9	268			
	Min.	77								86	99													69	109
	End	98										112	136											83	156

Note: All Published Torques are Guaranteed Minimum Values. Units are Metric

Torque - Pneumatic Spring-Return Actuator

Actuator Model	Spring Torque Start/Min./End (Nm)	Operating Pressure, (barg)																MinOP (barg)	Torque @ MinOP (Nm)	MOP (barg)	Torque @ MOP (Nm)			
		2.5	3	3.5	3.8	4	4.5	5	5.5	6	7	7.5	8.5	9	10	10.5	11					11.5		
		Pressure Torque Output: Start/Min./End (Nm)																						
CBB420-SR40	Start	86	Please consult factory	112	143	161	173	204	235	266	296	358	389	450	481	543	573	Exceeds MOP	2.6	87	10.8	592		
	Min	34		44	60	70	76	92	107	123	138	169	185	216	232	263	278			31		288		
	End	44		60	89	106	118	146	175	204	233	290	319	377	405	463	492			37		509		
CBB420-SR60	Start	137	Please consult factory		130	143	173	204	235	266	327	358	419	450	512	543	Exceeds MOP	3.8	130	10.8	561			
	Min	56			46	53	69	84	100	116	147	163	194	209	241	256			46		266			
	End	75			54	66	95	123	152	181	239	267	325	354	411	440			54		457			
CBB420-SR80	Start	187	Please consult factory					178	209	239	301	332	393	424	486	516	547	Exceeds MOP	5.0	178	11.1	553		
	Min	75						62	79	95	126	142	173	189	220	236	251			62		254		
	End	102						73	102	131	189	217	275	304	361	390	419			73		425		
CBB420-SR100	Start	243	Please consult factory								274	304	366	397	458	489	520	Exceeds MOP	6.3	231	11.4	545		
	Min	97									102	118	150	166	197	213	228			79		241		
	End	129									132	161	219	248	305	334	363			92		386		
CBB520-SR40	Start	143	Please consult factory	184	232	261	281	329	377	426	474	571	619	Exceeds MOP					2.6	145	7.6	629		
	Min	55		71	96	111	121	146	170	195	219	269	293							51		298		
	End	68		94	139	167	185	230	276	322	367	458	504							57		513		
CBB520-SR60	Start	217	Please consult factory		204	224	272	320	368	417	513	562	Exceeds MOP					3.7	195	8.0	610			
	Min	90			75	85	110	135	160	184	233	258							69		283			
	End	125			92	110	156	201	247	292	383	429							83		474			
CBB520-SR80	Start	298	Please consult factory					280	328	377	473	522	Exceeds MOP					5.0	280	8.3	599			
	Min	121						100	125	150	200	225							100		264			
	End	165						120	165	211	302	348							120		421			
CBB520-SR100	Start	408	Please consult factory								394	442	539	587	Exceeds MOP				6.7	365	9.1	597		
	Min	170									147	173	223	247						223		247	132	252
	End	245									192	237	328	374						328		374	164	383

Note: All Published Torques are Guaranteed Minimum Values. Units are Metric

Torque - Pneumatic Spring-Return Actuator

Actuator Model	Spring Torque Start/Min./End (Nm)	Operating Pressure, (barg)																MinOP (barg)	Torque @ MinOP (Nm)	MOP (barg)	Torque @ MOP (Nm)			
		2.5	3	3.5	3.8	4	4.5	5	5.5	6	7	7.5	8.5	9	10	10.5	11					11.5		
		Pressure Torque Output: Start/Min./End (Nm)																						
CBB525-SR40	Start	167	140	198	256	291	314	372	430	488	546	662	720	836	894	1,010	Exceeds MOP		2.4	128	10.1	1,022		
	Min.	71	58	89	120	139	151	182	212	243	273	335	365	426	457	518				52		524		
	End	103	80	139	197	233	256	315	374	433	492	610	669	787	846	964				68		976		
CBB525-SR60	Start	270			Please consult factory	239	262	320	378	436	494	610	668	784	842	958	Exceeds MOP		3.7	227	10.4	1,005		
	Min.	110				96	108	140	171	201	232	293	324	385	416	477				90		502		
	End	155				129	153	212	271	329	388	506	565	683	742	860				117		907		
CBB525-SR80	Start	376						Please consult factory	324	382	440	556	614	730	788	904	962	1,020	Exceeds MOP	4.9	312	11.0	1,020	
	Min.	151							126	157	188	250	281	343	373	435	465	496			119		496	
	End	210							164	223	282	400	459	577	636	754	813	872			153		872	
CBB525-SR100	Start	473									Please consult factory	497	555	671	729	846	904	962	Exceeds MOP	6.1	393	11.2	985	
	Min.	191										208	239	301	332	393	424	455			151		467	
	End	269										302	361	479	538	656	715	774			196		798	
CBB725-SR40	Start	363	298	413	528	598	644	759	874	990	1,105	1,336	Exceeds MOP						2.5	298	7.0	1,336		
	Min.	151	118	180	241	278	302	363	424	485	546	667								118		667		
	End	215	156	273	390	460	507	624	741	858	975	1,209								156		1,209		
CBB725-SR60	Start	574			Please consult factory	483	530	645	760	876	991	1,222	1,337	Exceeds MOP						3.8	483	7.9	1,430	
	Min.	233				188	214	276	337	398	459	581	642								188		691	
	End	330				249	296	413	530	647	764	998	1,115								249		1,209	
CBB725-SR80	Start	771						Please consult factory	649	764	880	1,111	1,226	1,457	Exceeds MOP						5.0	649	8.5	1,457
	Min.	312							251	314	376	499	560	682						251		682		
	End	441							332	449	566	800	917	1,151						332		1,151		
CBB725-SR100	Start	1,016									Please consult factory	1,029	1,144	1,375	Exceeds MOP						6.5	913	8.5	1,375
	Min.	391										406	468	592						343		592		
	End	524										555	672	906						438		906		

Note: All Published Torques are Guaranteed Minimum Values. Units are Metric

Torque - Pneumatic Spring-Return Actuator

Actuator Model	Spring Torque Start/Min./End (Nm)	Operating Pressure, (barg)																MinOP (barg)	Torque @ MinOP (Nm)	MOP (barg)	Torque @ MOP (Nm)															
		2.5	3	3.5	3.8	4	4.5	5	5.5	6	7	7.5	8.5	9	10	10.5	11					11.5														
Pressure Torque Output: Start/Min./End (Nm)																																				
CBA730-SR40	Start	459	385	531	677	765	823	969	1,115	1,260	1,406	1,698	1,844	2,136	2,282	Exceeds MOP				2.4	356	9.3	2,370													
	Min	187	150	228	306	352	383	460	537	614	691	844	921	1,074	1,151								134	1,197												
	End	259	192	339	487	575	634	782	929	1,077	1,224	1,519	1,667	1,962	2,110								162	2,198												
CBA730-SR60	Start	724			Please consult factory	631	689	835	981	1,127	1,273	1,565	1,711	2,003	2,149	Exceeds MOP				3.6	573	9.7	2,353													
	Min	287				241	273	352	429	507	584	738	815	969	1,046								209	1,153												
	End	393				309	368	516	663	811	958	1,254	1,401	1,696	1,844								250	2,050												
CBA730-SR80	Start	1,022			Please consult factory				885	1,031	1,177	1,469	1,615	1,906	2,052	2,344	Exceeds MOP			5.0	885	10.0	2,344													
	Min	382				313	394	473	629	707	862	939	1,093										313	1,093												
	End	489				365	513	660	955	1,103	1,398	1,545	1,841										365	1,841												
CBA730-SR100	Start	1,282			Please consult factory							1,338	1,484	1,776	1,922	2,214	Exceeds MOP			6.2	1,104	10.3	2,301													
	Min	481				519	598	755	832	987													390	1,034												
	End	620				694	841	1,136	1,284	1,579													458	1,668												
CBA830-SR40	Start	609	517	708	900	1,015	1,092	1,283	1,475	1,667	1,858	2,242	Exceeds MOP						2.4	478	7.2	2,318														
	Min	248	201	304	406	467	508	609	710	811	911	1,113										180	1,153													
	End	346	261	454	648	764	842	1,036	1,229	1,423	1,617	2,004										222	2,082													
CBA830-SR60	Start	989			Please consult factory	876	952	1,144	1,336	1,527	1,719	2,102	2,294	Exceeds MOP						3.7	837	7.6	2,333													
	Min	375				318	360	465	567	669	771	974	1,075										296	1,095												
	End	486				384	461	655	849	1,043	1,236	1,624	1,818										345	1,856												
CBA830-SR80	Start	1,357			Please consult factory				1,184	1,376	1,568	1,951	2,143	Exceeds MOP						5.0	1,184	7.9	2,296													
	Min	503				414	521	625	831	933													414	1,014												
	End	637				479	673	867	1,254	1,448													479	1,603												
CBA830-SR100	Start	1,737			Please consult factory							1,811	2,003	Exceeds MOP						6.3	1,543	8.3	2,310													
	Min	629				680	785																531	950												
	End	777				874	1,067																602	1,377												

Note: All Published Torques are Guaranteed Minimum Values. Units are Metric

Torque - Pneumatic Spring-Return Actuator

Actuator Model	Spring Torque Start/Min./End (Nm)	Operating Pressure, (barg)																MinOP (barg)	Torque @ MinOP (Nm)	MOP (barg)	Torque @ MOP (Nm)		
		2.5	3	3.5	3.8	4	4.5	5	5.5	6	7	7.5	8.5	9	10	10.5	11					11.5	
		Pressure Torque Output: Start/Min./End (Nm)																					
CBA930-SR40	Start	783	666	910	1,153	1,300	1,397	1,641	1,884	2,128	Exceeds MOP									2.4	618	5.9	2,323
	Min	318	259	390	519	597	648	777	905	1,033		232	1,136										
	End	445	338	584	830	977	1,076	1,322	1,568	1,814		288	2,011										
CBA930-SR60	Start	1,290			Please consult factory	1,156	1,254	1,497	1,741	1,985	2,228	Exceeds MOP								3.8	1,156	6.2	2,326
	Min	473				405	460	593	724	854	984		405	1,035									
	End	588				469	567	814	1,060	1,306	1,552		469	1,651									
CBA930-SR80	Start	1,736			Please consult factory				1,523	1,766	2,010	Exceeds MOP								5.0	1,523	6.6	2,302
	Min	640				531	666	799	531	666	799		531	956									
	End	807				613	859	1,105	613	859	1,105		613	1,400									
CBA930-SR100	Start	2,184			Please consult factory							2,275	Exceeds MOP							6.3	1,933	7.2	2,372
	Min	809				870	682	923															
	End	1,030				1,148	803	1,247															
CBA1030-SR40	Start	1,053	902	1,224	1,546	1,740	1,868	2,191	Exceeds MOP											2.4	838	4.8	2,384
	Min	423	346	520	691	794	862	1,032		311	1,133												
	End	587	449	774	1,099	1,295	1,425	1,750		383	1,945												
CBA1030-SR60	Start	1,733			Please consult factory	1,573	1,702	2,024	2,346	Exceeds MOP										3.8	1,573	5.2	2,475
	Min	622				541	614	790	964		541	1,033											
	End	755				612	743	1,068	1,393		612	1,524											
CBA1030-SR80	Start	2,261			Please consult factory				1,968	2,291	Exceeds MOP									4.9	1,904	5.5	2,291
	Min	860				711	888	711	888	711		888	675	888									
	End	1,133				864	1,189	864	1,189	864		1,189	799	1,189									

Note: All Published Torques are Guaranteed Minimum Values. Units are Metric

World Area Configuration Centers (WACC) offer sales support, service, inventory and commissioning to our global customers. Choose the WACC or sales office nearest you:

NORTH & SOUTH AMERICA

19200 Northwest Freeway
Houston TX 77065
USA
T +1 281 477 4100

Av. Hollingsworth
325 Iporanga Sorocaba
SP 18087-105
Brazil
T +55 15 3413 8888

ASIA PACIFIC

No. 9 Gul Road
#01-02 Singapore 629361
T +65 6777 8211

No. 1 Lai Yuan Road
Wuqing Development Area
Tianjin 301700
P. R. China
T +86 22 8212 3300

MIDDLE EAST & AFRICA

P. O. Box 17033
Jebel Ali Free Zone
Dubai
T +971 4 811 8100

P. O. Box 10305
Jubail 31961
Saudi Arabia
T +966 3 340 8650

24 Angus Crescent
Longmeadow Business Estate East
P.O. Box 6908 Greenstone
1616 Modderfontein Extension 5
South Africa
T +27 11 451 3700

EUROPE

Holland Fásor 6
Székesfehérvár 8000
Hungary
T +36 22 53 09 50

Strada Biffi 165
29017 Fiorenzuola d'Arda (PC)
Italy
T +39 0523 944 411

For complete list of sales and manufacturing sites, please visit www.emerson.com/actuationtechnologieslocations or contact us at info.actuationtechnologies@emerson.com

www.emerson.com/bettis

©2018 Emerson. All rights reserved.

The Emerson logo is a trademark and service mark of Emerson Electric Co. Bettis™ is a mark of one of the Emerson family of companies. All other marks are property of their respective owners.

The contents of this publication are presented for information purposes only, and while every effort has been made to ensure their accuracy, they are not to be construed as warranties or guarantees, express or implied, regarding the products or services described herein or their use or applicability. All sales are governed by our terms and conditions, which are available on request. We reserve the right to modify or improve the designs or specifications of our products at any time without notice.

Sizing and Selection

General Definitions

To clarify and standardize terminology, Bettis offers the following definitions for terms commonly used. Please become familiar with and use the following standard definitions when referring to Bettis quarter-turn actuators.

Quarter-turn: A device which rotates a minimum of 90 degrees.

All Bettis quarter-turn actuators will rotate more than 90 degrees.

Position: That degree of rotation describing an actuator's current location. The mid position of a quarter-turn actuator is generally at forty-five (45) degrees.

CW: Clockwise rotation.

CCW: Counterclockwise rotation.

Stroke: A continuous, ninety (90) degree rotation of a quarter-turn actuator. Bettis spring-return actuators have two (2) different strokes, a pressure stroke and a spring stroke. Bettis double-acting actuators have two (2) pressure strokes. Note that rack and pinion actuators have common torque valves for both pressure strokes, while scotch yoke actuators have different torque values depending on which side of the piston is doing the work.

Cycle: The collective reference to two (2) strokes, one (1) for clockwise (CW) rotation and one (1) for counterclockwise (CCW) rotation. Bettis actuators must rotate through two (2) stroke to complete one (1) cycle.

Safety Factor: Represents a protective component (an adjustment to torque requirement) sometimes added to a valve's required torque value. Often used when the user/specifier is not certain of the valve's torque requirements, or because of other application concerns.

Sizing Bettis Actuators

The following information is generally the minimum required for sizing Bettis quarter-turn pneumatic and hydraulic actuators for specific valve requirements.

A) An accurate maximum torque requirement must be obtained before actuator sizing begins. Normal maximum stem torque for a properly applied and maintained valve is usually defined as: The maximum starting torque required to rotate the valve element (ball, disc, plug, etc.) from a fully closed position (unsealing), against the maximum normal valve rated different pressures. Most valve manufacturers make adjustments in the form of torque amendments under various operating conditions. Application operating conditions such as temperature extremes, actual differential pressure, unusual loading, high flow rates, operating speeds, etc. are some of the most common causes for adjustments.

Bettis recommends that the valve manufacturer supply the maximum required torque value(s) **(including any adjustments or suggested safety factors)**. Additionally, the valve manufacturer must identify at which position(s) and direction(s) of rotation (CCW or CW) these maximum requirements occur.

B) Bettis actuators include stops which will resist the maximum rated torque output of the actuator. The possibility exists, that should the valve become immobilized during rotation, the actuator could exceed the maximum allowable valve input torque rating. If this possibility is a concern, your application needs further review.

Once the maximum torque requirements, its position, and direction of rotation are identified, the appropriate Bettis actuator can be selected from torque output charts.



Sizing and Selection

Actuator Selection Procedures

- A) Determine the type of Bettis actuator required: double-acting or spring-return.
- B) Determine the power supply media: pneumatic or hydraulic, and the minimum/maximum supply pressure(s) at the actuator.
- C) Using this information, select the applicable torque rating table and see the appropriate following examples.

Scotch-Yoke, Double-Acting Actuators (example assumes CW to close)

Note: The valve's torque requirements must be exceeded by the actuator's torque output at all corresponding positions and directions of rotation.

Bettis has included Start, Minimum, and End pressure torque outputs for your use.

- A) Using your minimum operating pressure, select an operating pressure column from the Pressure Torque Rating Section of less than or equal pressure. Move down the column until both starting and minimum output torques are found which exceed the valve's maximum and minimum torque requirements. Determine the Bettis model number at the left, under the model number column.
- B) Once a Bettis actuator model has been selected, use the performance data tables to ensure your maximum supply pressure does not exceed the maximum operating pressure (M.O.P.) for your Bettis actuator. If the actuator selected is not rated for your maximum supply pressure, either the maximum supply pressure must be reduced or an actuator rated for a higher M.O.P. must be selected.

Scotch-Yoke, Spring-Return, Fail CLOCKWISE Actuators (example assumes CW to close)

Note: The valve's maximum torque requirements must be exceeded by the actuator's torque output at all corresponding positions and directions of rotation.

Bettis has included Start, Minimum, and End Spring Torque outputs, as well as Start, Minimum and End Pressure Torque Outputs for your use. The minimum torque outputs listed on the Spring-Return torque charts are the lowest value of torque output available at any position, during either stroke (pressure or spring).

- A) Select from the Spring Torque column a Spring Ending torque output which exceeds that of the valve's maximum seating requirement.
- B) Proceed to the right using your minimum operating pressure and select an operating pressure column from the Pressure Torque Rating Section of less than or equal pressure. The Pressure Start torque output must exceed the valve's torque requirement at this position (unseating). The Pressure End torque output must exceed the valve's torque requirement at this position (full flow) and direction of rotation (CCW).
- C) Once a Bettis actuator model has been selected, use the performance data tables to ensure your maximum supply pressure does not exceed the maximum operating pressure (M.O.P.) for your Bettis actuator. If the actuator selected is not rated for your maximum supply pressure, either the maximum supply pressure must be reduced or an actuator rated for a higher M.O.P. must be selected.

Contact your local Authorized Bettis distributor or a Bettis manufacturing facility if you require assistance.



www.Bettis.com

Copyright © Emerson Process Management. The information in this document is subject to change without notice. Updated data sheets can be obtained from our website www.bettis.com or from your nearest Valve Automation Center.
USA: +1 281 727 5300 Europe: +31 74 256 1010 Asia-Pacific: +65 6501 4600



Data sheet

Sheet No.: CBPM 3.01 Rev. D

Date: April 2018

CBB-Series

Dimensions – (Pneumatic) mm.

Double-Acting Actuators CBBXXX

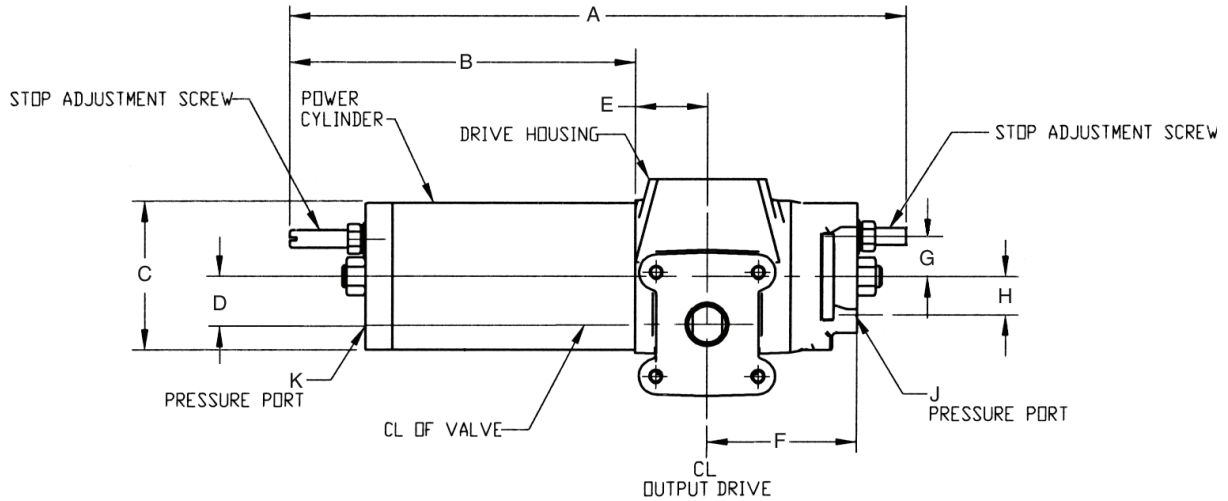

Actuator Model	A	B	C	D	E	F	G	H	J/K	L	M	N
CBB315	359.8	187.5	82.6	25.4	47.8	87.9	23.9	23.9	1/4" NPT	.313-18 UNC	9.7	57.2
CBB420	417.3	217.6	108.0	36.6	54.1	111.0	27.9	27.9	3/8" NPT	.375-16 UNC	12.7	76.2
CBB520	418.1	219.2	136.7	36.6	52.5	111.0	27.9	27.9	3/8" NPT	.375-16 UNC	12.7	76.2
CBB525	488.1	250.9	136.7	36.6	65.0	127.0	31.8	31.8	3/8" NPT	.500-13 UNC	12.7	88.9
CBB725	492.7	260.1	190.5	44.5	64.2	127.0	31.8	31.8	3/8" NPT	.500-13 UNC	12.7	88.9

Actuator Model	P	Q	R	S	T	U	V	W	X	Y	Z	AA
CBB315	.313-18 UNC	28.6	73.8	147.6	19.1	56.4	131.5	15.59 15.75	26.2	95.3	27.8	22.15 22.25
CBB420	.375-16 UNC	38.1	85.1	169.9	19.1	71.4	158.9	21.94 22.10	26.2	117.5	35.1	28.5 28.6
CBB520	.375-16 UNC	38.1	85.1	169.9	19.1	71.4	158.9	21.94 22.10	26.2	117.5	35.1	28.5 28.6
CBB525	.500-13 UNC	44.5	111.1	222.3	28.4	88.9	192.6	28.32 28.48	38.1	146.1	42.9	38.02 38.12
CBB725	.500-13 UNC	44.5	111.1	222.3	28.4	88.9	192.6	28.32 28.48	38.1	146.1	42.9	38.02 38.12

Note: Not Certified dimensional drawings. Such drawings available on request.
Contact factory with correct model designation and serial number.
All dimensions are expressed in millimeters.

BETTIS

EMERSON

Copyright © Emerson. The information in this document is subject to change without notice. Updated data sheets can be obtained from our website www.emerson.com/bettis or from your Emerson Automation Solutions - Actuation Technologies Center:
America's: +1 281 477 4100 Europe: +36 22 53 0950 Asia/Pacific: +65 67 77 8211 Middle East: +971 4 811 810

Data sheet

Sheet No.: CBPM 3.02 Rev. D

Date: April 2018

CBB-Series

Dimensions – (Pneumatic) mm.

Double-Acting Actuators
CBBXXX (cont.)

ACTUATORS SHOWN ROTATED
TO FULL CLOCKWISE POSITION

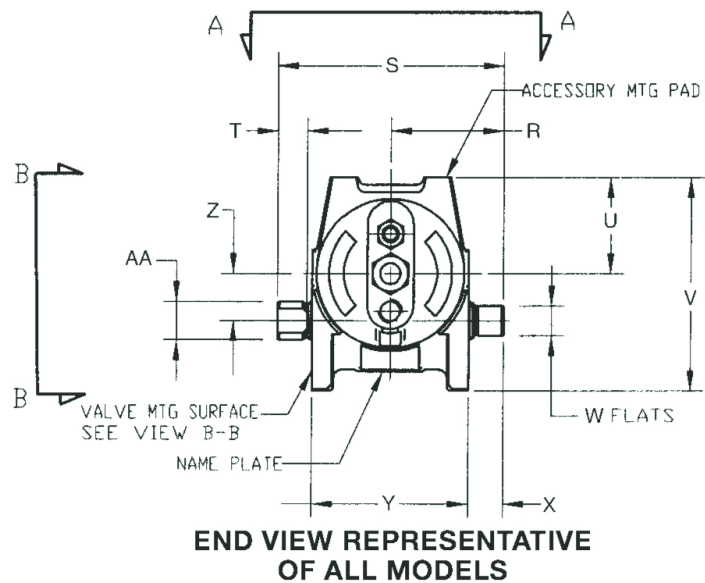
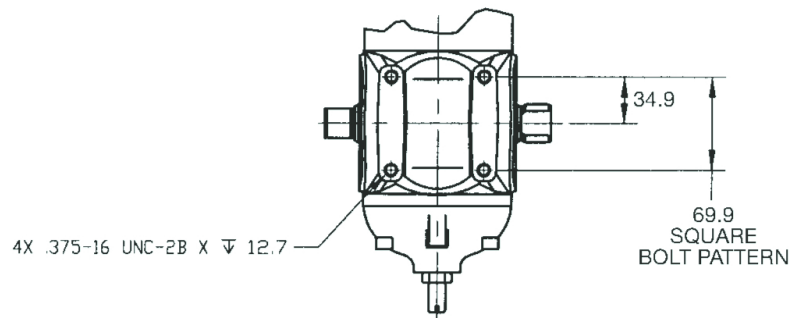
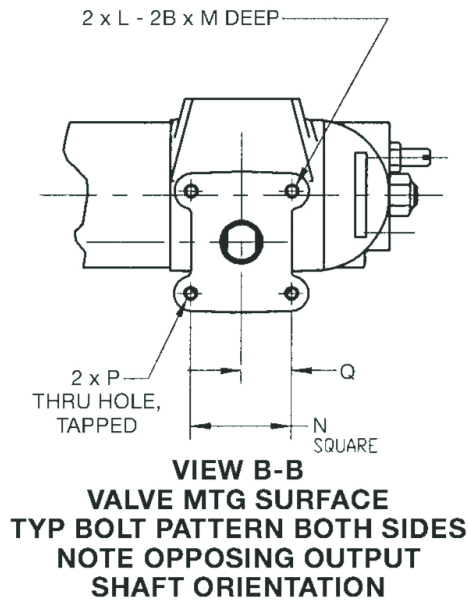

Note: Not Certified dimensional drawings. Such drawings available on request.
Contact factory with correct model designation and serial number.
All dimensions are expressed in millimeters.

BETTIS™



EMERSON™

Copyright © Emerson. The information in this document is subject to change without notice. Updated data sheets can be obtained from our website www.emerson.com/bettis or from your Emerson Automation Solutions - Actuation Technologies Center:
America's: +1 281 477 4100 Europe: +36 22 53 0950 Asia/Pacific: +65 67 77 8211 Middle East: +971 4 811 810

Data sheet

Sheet No.: CBPM 3.03 Rev. D

Date: April 2018

CBB-Series

Dimensions – (Pneumatic) mm.

Spring-Return Actuators CBB XXX-SRX

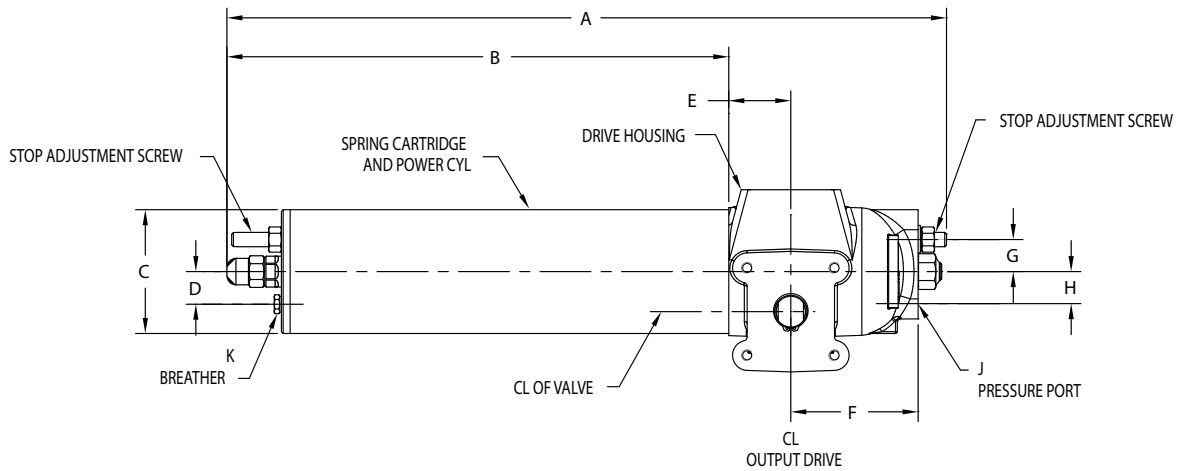

Actuator Model	A	B	C	D	E	F	G	H	J/K	L
CBB315-SRX	528.4	365.8	82.6	23.9	47.8	87.9	23.8	23.9	1/4" NPT	.313-18 UNC
CBB415-SRX	532.1	367.2	108.0	28.4	47.8	87.9	23.8	23.9	1/4" NPT	.313-18 UNC
CBB420-SRX	627.5	437.6	108.0	28.4	54.1	111.0	27.9	27.9	3/8" NPT	.375-16 UNC
CBB520-SRX	631.9	442.9	136.7	31.8	52.5	111.0	27.9	27.9	3/8" NPT	.375-16 UNC
CBB525-SRX	716.6	491.5	136.7	31.8	65.0	127.0	31.8	31.8	3/8" NPT	.500-13 UNC
CBB725-SRX	713.6	493.2	190.5	63.5	64.2	127.0	31.8	31.8	3/8" NPT	.500-13 UNC

Actuator Model	M	N	P	Q	R	S	T	U	V	W	X	Y	Z	AA
CBB315-SRX	9.7	57.2	.313-18 UNC	28.6	73.8	147.6	19.1	56.4	131.5	15.6 15.73	26.2	95.3	27.8	22.15 22.25
CBB415-SRX	9.7	57.2	.313 -18 UNC	28.6	73.8	147.6	19.1	56.4	131.5	15.59 15.75	26.2	95.3	27.8	22.12 22.22
CBB420-SRX	12.7	76.2	.375 -16 UNC	38.1	85.1	169.9	19.1	71.4	158.9	22.09 21.09	26.2	117.5	35.1	28.5 28.6
CBB520-SRX	12.7	76.2	.375 -16 UNC	38.1	85.1	169.9	19.1	71.4	158.9	22.09 21.09	26.2	117.5	35.1	28.5 28.6
CBB525-SRX	12.7	88.9	.500 -13 UNC	44.5	111.1	222.3	28.4	88.9	192.6	28.33 24.47	38.1	146.1	42.9	38.02 38.12
CBB725-SRX	12.7	88.9	.500 -13 UNC	44.5	111.1	222.3	28.4	88.9	192.6	28.32 28.48	38.1	146.1	42.9	38.02 38.12

Note: Not Certified dimensional drawings. Such drawings available on request.
Contact factory with correct model designation and serial number.
All dimensions are expressed in millimeters.

BETTIS™

EMERSON™

Copyright © Emerson. The information in this document is subject to change without notice. Updated data sheets can be obtained from our website www.emerson.com/bettis or from your Emerson Automation Solutions - Actuation Technologies Center:
America's: +1 281 477 4100 Europe: +36 22 53 0950 Asia/Pacific: +65 67 77 8211 Middle East: +971 4 811 810

Data sheet

Sheet No.: CBPM 3.04 Rev. D

Date: April 2018

CBB-Series

Dimensions – (Pneumatic) mm.

Spring-Return Actuators

CBB XXX-SRX (cont.)

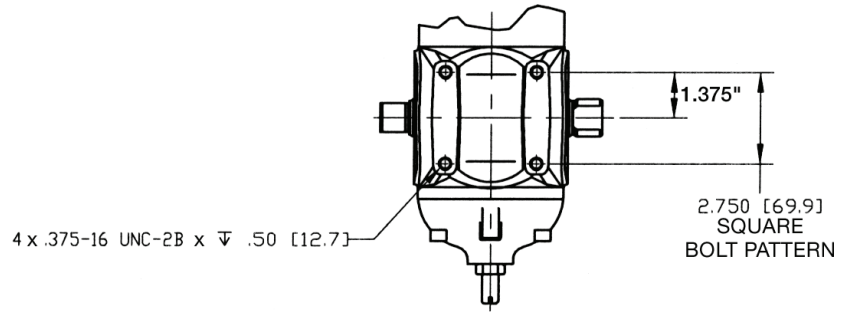

ACTUATORS SHOWN ROTATED
TO FULL CLOCKWISE POSITION

**VIEW A-A
ACCY MTG PAD**

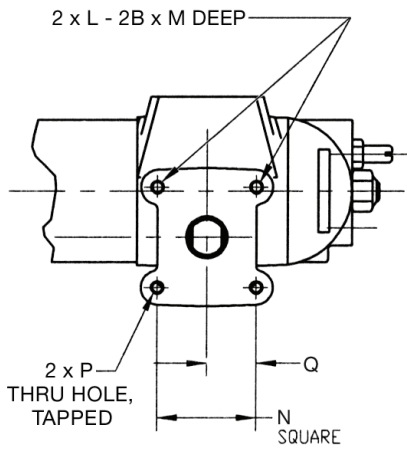

**VIEW B-B
VALVE MTG SURFACE
TYP BOLT PATTERN BOTH SIDES
NOTE OPPOSING OUTPUT
SHAFT ORIENTATION**

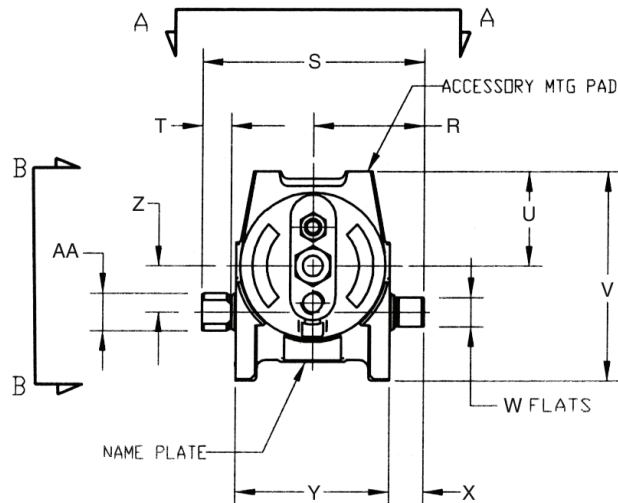

**END VIEW REPRESENTATIVE
OF ALL MODELS**

Note: Not Certified dimensional drawings. Such drawings available on request.
Contact factory with correct model designation and serial number.
All dimensions are expressed in millimeters.

BETTIS™



Copyright © Emerson. The information in this document is subject to change without notice. Updated data sheets can be obtained from our website www.emerson.com/bettis or from your Emerson Automation Solutions - Actuation Technologies Center.
America's: +1 281 477 4100 Europe: +36 22 53 0950 Asia/Pacific: +65 67 77 8211 Middle East: +971 4 811 810

Data sheet

Sheet No.: CBPM 3.05 Rev. D

Date: April 2018

CBB-Series

Dimensions – (Pneumatic) mm.

M3(HW) Override

Double-Acting Actuators

CBB XXX-M3(HW)

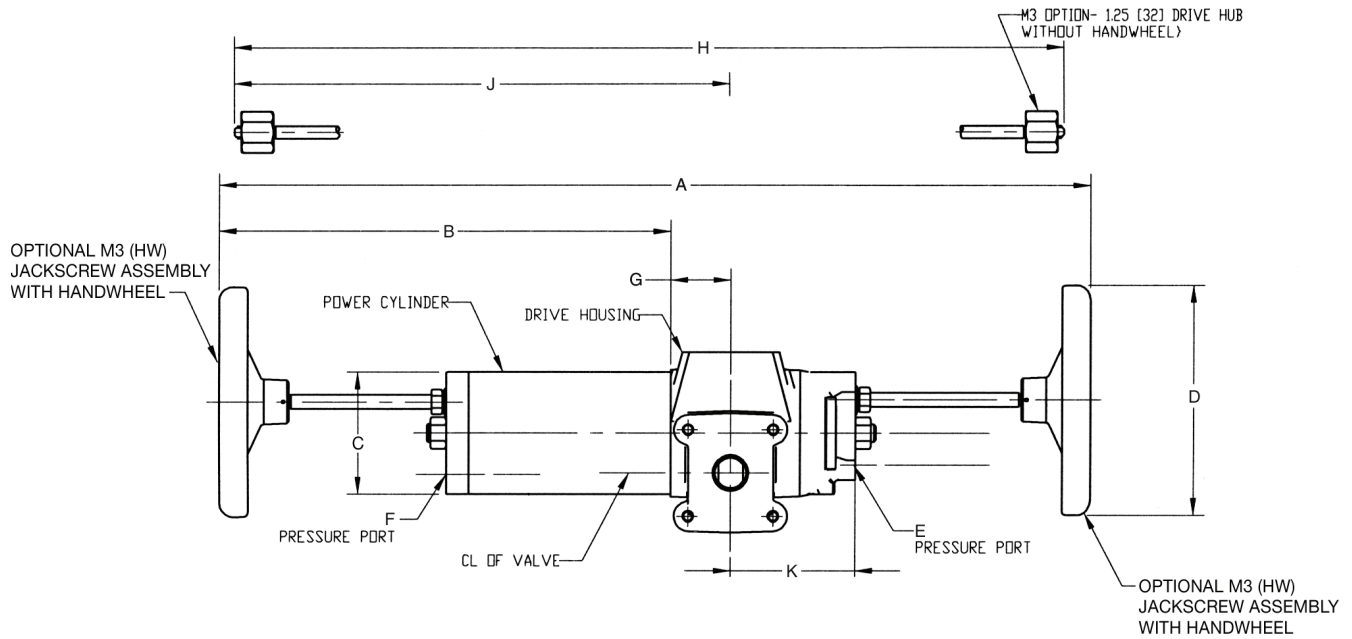

Actuator Model	A	B	C	D	E	F	G	H	J	K
CBB315-M3HW	666.8	350.3	82.6	152.4	1/4" NPT	1/4" NPT	47.8	639.6	384.3	87.9
CBB420-M3HW	792.5	410.2	108.0	203.2	3/8" NPT	3/8" NPT	54.1	741.9	438.9	111.0
CBB520-M3HW	792.5	411.7	136.7	203.2	3/8" NPT	3/8" NPT	52.5	741.9	438.9	111.0
CBB525-M3HW	945.6	493.8	136.7	254.0	3/8" NPT	3/8" NPT	65.0	861.1	510.0	127.0
CBB725-M3HW	945.6	494.5	190.5	254.0	3/8" NPT	3/8" NPT	64.2	880.1	526.0	127.0

Note: Not Certified dimensional drawings. Such drawings available on request.

Contact factory with correct model designation and serial number.

All dimensions are expressed in millimeters.

BETTIS™

EMERSON™

Copyright © Emerson. The information in this document is subject to change without notice. Updated data sheets can be obtained from our website www.emerson.com/bettis or from your Emerson Automation Solutions - Actuation Technologies Center:

America's: +1 281 477 4100 Europe: +36 22 53 0950 Asia/Pacific: +65 67 77 8211 Middle East: +971 4 811 810

Data sheet

Sheet No.: CBPM 3.06 Rev. D

Date: April 2018

CBB-Series

Dimensions – (Pneumatic) mm.

M3(HW) Override

Spring-Return Actuators

CBB XXX-SRX-M3

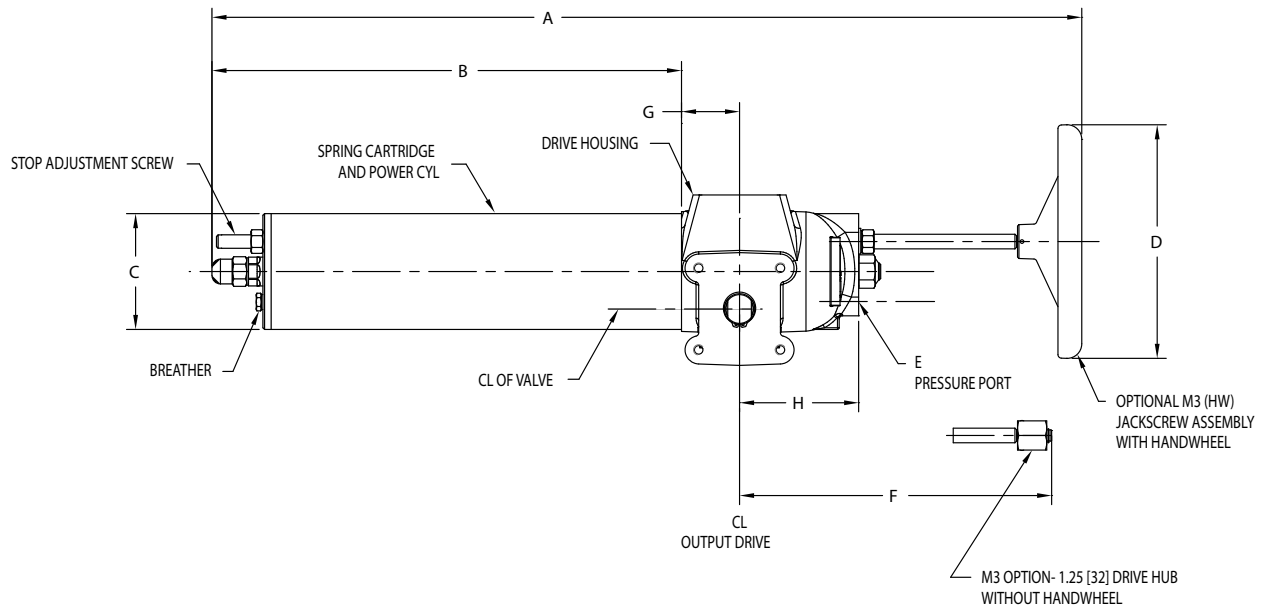

Actuator Model	A	B	C	D	E	F	G	H
CBB315-SR-M3HW	682.5	365.8	82.6	152.4	1/4" NPT	255.3	47.8	87.9
CBB415-SR-M3HW	683.9	367.2	108.0	152.4	1/4" NPT	255.3	47.8	87.9
CBB420-SR-M3HW	820.0	437.6	108.0	203.2	3/8" NPT	303.0	54.1	111.0
CBB520-SR-M3HW	823.7	442.9	136.7	203.2	3/8" NPT	303.0	52.5	111.0
CBB525-SR-M3HW	943.4	491.6	136.7	254.0	3/8" NPT	354.1	65.0	127.0
CBB725-SR-M3HW	944.1	493.2	190.5	254.0	3/8" NPT	354.1	64.2	127.0

Note: Not Certified dimensional drawings. Such drawings available on request.
 Contact factory with correct model designation and serial number.
 All dimensions are expressed in millimeters.

BETTIS

EMERSON

Copyright © Emerson. The information in this document is subject to change without notice. Updated data sheets can be obtained from our website www.emerson.com/bettis or from your Emerson Automation Solutions - Actuation Technologies Center:
 America's: +1 281 477 4100 Europe: +36 22 53 0950 Asia/Pacific: +65 67 77 8211 Middle East: +971 4 811 810

Data sheet

Sheet No.: CBPI 2.01 RevB

Date: February 2010

CBB-Series

Performance Data – (Pneumatic)

Double-Acting Actuators CBB-Series

Actuator Model	Volume				Maximum Operating Pressure (MOP)*		Maximum Allowable Working Pressure (MAWP)**		Approximate Weight of Actuator	
	Outboard		Inboard (Housing)		PSIG	Bar	PSIG	Bar	Lbs.	Kg
	Cu. Inches	Cubic Cm	Cu. Inches	Cubic Cm						
CBB 315	24	393.3	54	885.0	120	8.3	200	13.8	20	9.1
CBB 420	53	868.5	115	1884.5	120	8.3	200	13.8	22	10.0
CBB 520	83	1360.1	148	2425.3	70	4.8	160	11.0	28	12.7
CBB 525	105	1720.6	207	3392.1	120	8.3	200	13.8	44	20.0
CBB 725	208	3408.5	327	5358.6	80	5.5	160	11.0	68	31.0

Spring-Return Actuators CBB-Series

Actuator Model	Volume		Maximum Operating Pressure (MOP)*		Maximum Allowable Working Pressure (MAWP)**		Approximate Weight of Actuator	
	Cu. Inches	Cubic Cm	PSIG	Bar	PSIG	Bar	Lbs.	Kg
◆ CBB 315-SR40	54	885	155	10.7	200	13.8	22	10.0
SR60	54	885	152	10.5	200	13.8	23	10.4
SR80	54	885	150	10.3	200	13.8	26	11.8
SR100	54	885	164	11.3	200	13.8	25	11.4
◆ CBB 415-SR40	75	1229	100	6.9	160	11.0	27	12.7
SR60	75	1229	112	7.7	160	11.0	29	14.1
SR80	75	1229	117	8.1	160	11.0	30	14.1
SR100	75	1229	114	7.9	160	11.0	31	14.1
◆ CBB 420-SR40	115	1884.5	157	10.8	200	13.8	37	16.8
SR60	115	1884.5	156	10.8	200	13.8	39	17.7
SR80	115	1884.5	161	11.0	200	13.8	40	18.1
SR100	115	1884.5	166	11.4	200	13.8	41	18.6
◆ CBB 520-SR40	148	2425.3	110	7.6	160	11.0	45	20.4
SR60	148	2425.3	116	8.0	160	11.0	48	21.8
SR80	148	2425.3	120	8.3	160	11.0	49	22.2
SR100	148	2425.3	132	9.1	160	11.0	53	24.0
◆ CBB 525-SR40	207	3392	146	10.1	200	13.8	62	28.1
SR60	207	3392	151	10.4	200	13.8	65	29.5
SR80	207	3392	159	11.0	200	13.8	65	29.5
SR100	207	3392	163	11.2	200	13.8	67	30.4
◆ CBB 725-SR40	327	5358.6	102	7.0	160	11.0	97	44.0
SR60	327	5358.6	115	8.0	160	11.0	98	44.5
SR80	327	5358.6	124	8.6	160	11.0	104	47.2
SR100	327	5358.6	124	8.6	160	11.0	107	48.5

Notes:

- ◆ CBA-SRXXM mechanical handwheel overrides are available on these models. The override adds approximately 2 lbs. (.8 kg) to the weight of the standard CBA model.
 - ▲ Maximum volume including cavity required for calculating consumption per stroke.
 - * **Maximum Operating Pressure (MOP)** is the pressure required to produce the maximum rated torque of the actuator.
 - ** **Maximum Allowable Working Pressure (MAWP)** is the maximum static pressure that may be applied to a fully stroked actuator against the travel stops.
- Standard installation produces clockwise rotation when the outboard side of piston is pressurized.
 Standard installation produces counterclockwise rotation when the inboard side of piston is pressurized.
 Note: Actuator may be installed opposite of that shown above

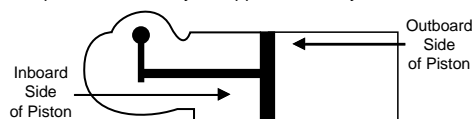

BETTIS[™]

www.Bettis.com

Copyright © Emerson Process Management. The information in this document is subject to change without notice.
 Updated data sheets can be obtained from our website www.bettis.com or from your nearest Valve Automation Center.
 USA: +1 281 727 5300 Europe: +31 74 256 1010 Asia-Pacific: +65 6501 4600

EMERSON[™]
 Process Management

Data sheet

Date: Rev. 03.10.14
DOC.DSB.CBB.UK

Bettis CBB-Series

Technical data sheet - Metric

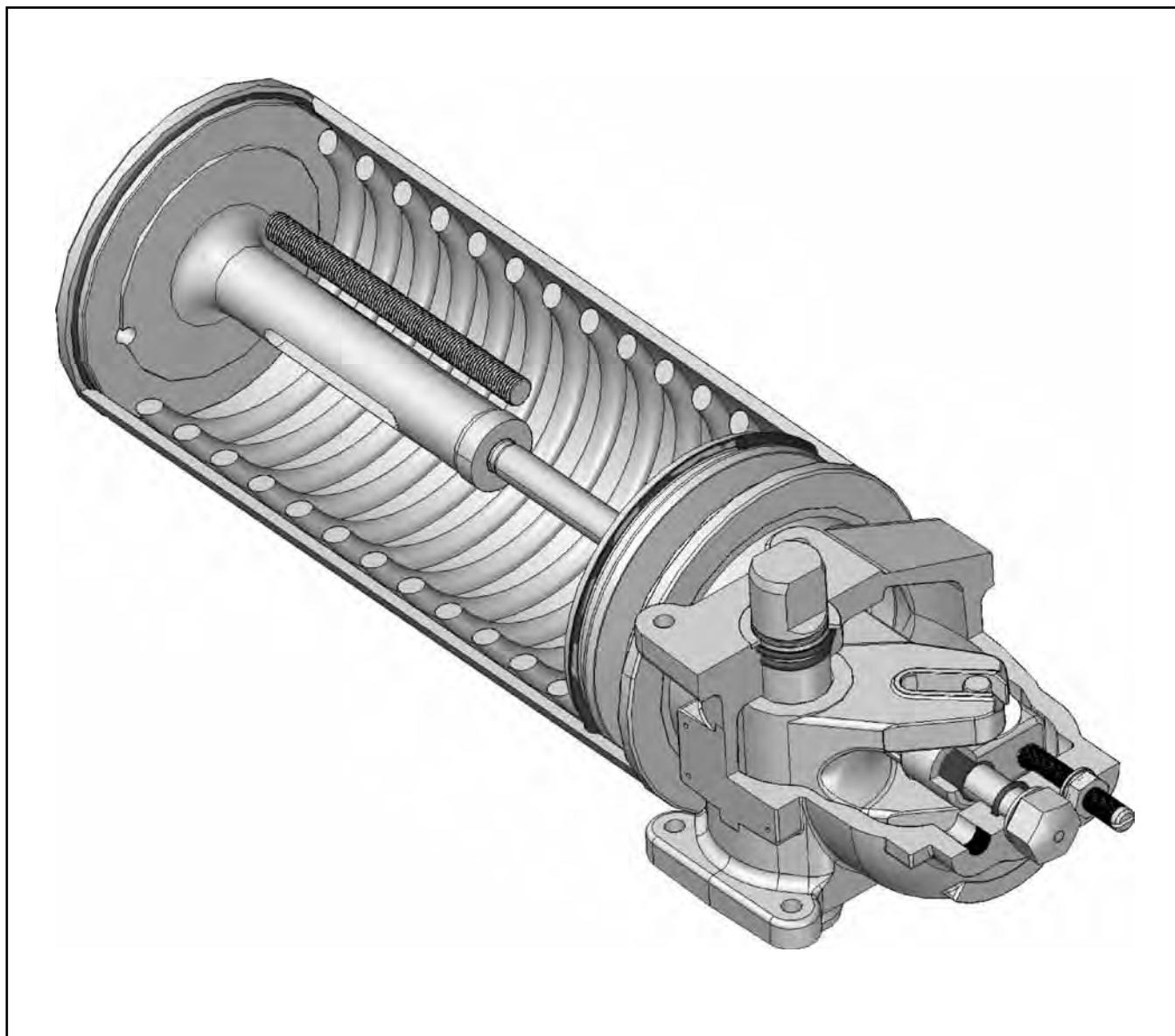

Data sheet

Sheet No.: CBPM 1.01 RevB

Date: February 2010

CBB-Series

Torque Ratings – (Pneumatic)

All Published Torques are Guaranteed Minimum Values.

Double-Acting Actuators

CBB-Series

Actuator Model	Stroke Position	Operating Pressure (Bar)							
		3	3.5	4	5	5.5	6	7	8
		Pressure Torque Output Start/Min./End (Nm)							
CBB 315	Start/End	83	97	111	139	153	167	194	222
	Minimum	50	58	66	83	91	99	116	133
CBB 420	Start/End	189	220	252	315	346	378	441	504
	Minimum	107	125	143	179	196	214	250	286
CBB 520	Start/End	262	306	350	437				
	Minimum	160	187	213	267				
CBB 525	Start/End	362	422	482	603	663	724	844	965
	Minimum	211	247	282	352	387	423	493	564
CBB725	Start/End	708	826	944	1179	1297			
	Minimum	422	492	563	703	774			

Spring-Return Actuators

CBB-Series

Actuator Model	Spring Torque Start/Min./End (Nm)	Operating Pressure (Bar)										
		3	3.5	4	5	5.5	6	7	8	9	10	11
		Pressure Torque Output Start/Min./End (Nm)										
CBB315 SR40	Start	39	49	61	74	100	113	125	151	177	202	228
	Min.	17	21	29	36	51	58	65	79	94	108	123
	End	23	31	44	57	84	97	110	136	162	189	215
CBB315 SR60	Start	68	51	65	93	107	121	148	176	204	232	
	Min.	27	18	26	41	49	57	72	87	102	117	
	End	34	21	35	63	76	90	118	146	174	202	
CBB315 SR80	Start	86			84	99	115	145	175	206	236	
	Min.	35			29	37	44	59	74	89	103	
	End	45			41	56	71	101	132	162	192	
CBB315 SR100	Start	121					93	122	151	180	209	238
	Min.	46					34	50	66	81	97	113
	End	56					42	71	100	129	159	188
Actuator Model	Spring Torque Start/Min./End (Nm)	Pressure Torque Output Start/Min./End (Nm)										
		3	3.5	4	5	5.5	6	7	8	9	10	11
		Operating Pressure (Bar)										



www.Bettis.com

Copyright © Emerson Process Management. The information in this document is subject to change without notice.

Updated data sheets can be obtained from our website www.bettis.com or from your nearest Valve Automation Center.

USA: +1 281 727 5300 Europe: +31 74 256 1010 Asia-Pacific: +65 6501 4600



EMERSON
Process Management

Data sheet

Sheet No.: CBPM 1.02 RevB

Date: February 2010

CBB-Series

Torque Ratings – (Pneumatic)

All Published Torques are Guaranteed Minimum Values.

Spring-Return Actuators

CBB-Series (cont.)

Actuator Model	Spring Torque Start/Min./End (Nm)	Operating Pressure (Bar)											
		3	3.5	4	5	5.5	6	7	8	9	10	11	
		Pressure Torque Output Start/Min./End (Nm)											
CBB415 SR40	Start	77	90	113	137	185	208	232	279				
	Min.	32	39	52	66	93	106	119	146				
	End	41	56	82	108	159	185	210	262				
CBB415 SR60	Start	122		82	104	150	173	195	241				
	Min.	49		31	45	73	87	100	127				
	End	65		36	61	111	136	161	211				
CBB415 SR80	Start	152				130	153	176	223	270			
	Min.	65				53	68	82	109	137			
	End	80				66	91	116	165	214			
CBB415 SR100	Start	187						182	232				
	Min.	76						54	84				
	End	85						54	102				
CBB420 SR40	Start	67	108	135	162	216	243	270	324	377	431	485	
	Min.	34	43	58	73	102	117	131	160	190	219	248	
	End	54	57	83	109	161	187	213	266	318	370	422	
CBB420 SR60	Start	149			143	200	229	258	316	374	431	489	
	Min.	54			50	81	97	112	143	173	204	234	
	End	78			56	107	132	158	208	259	310	360	
CBB420 SR80	Start	188				176	205	235	293	352	410	469	527
	Min.	74				61	77	94	126	158	191	223	255
	End	102				66	94	123	179	235	291	347	403
CBB420 SR100	Start	252						209	268	328	387	446	506
	Min.	94						64	100	134	166	199	232
	End	126						64	121	178	235	292	349
CBB520 SR40	Start	113	168	208	249	330	370	411	492				
	Min.	50	68	91	113	158	180	202	246				
	End	64	99	147	194	289	336	384	478				
CBB520 SR60	Start	194		161	203	286	328	370	453	537			
	Min.	84		58	83	132	156	180	229	277			
	End	109		62	110	205	252	299	394	489			
CBB520 SR80	Start	291				256	299	342	428	514			
	Min.	115				98	125	150	201	251			
	End	140				118	167	216	315	413			
CBB520 SR100	Start	438						268	356	443	530		
	Min.	154						84	138	187	236		
	End	194						84	178	273	368		
Actuator Model	Spring Torque Start/Min./End (Nm)	Pressure Torque Output Start/Min./End (Nm)											
		3	3.5	4	5	5.5	6	7	8	9	10	11	
		Operating Pressure (Bar)											



www.Bettis.com

Copyright © Emerson Process Management. The information in this document is subject to change without notice. Updated data sheets can be obtained from our website www.bettis.com or from your nearest Valve Automation Center. USA: +1 281 727 5300 Europe: +31 74 256 1010 Asia-Pacific: +65 6501 4600



Data sheet

Sheet No.: CBPM 1.03 RevB

Date: February 2010

CBB-Series

Torque Ratings – (Pneumatic)

All Published Torques are Guaranteed Minimum Values.

Spring-Return Actuators

CBB-Series (cont.)

Actuator Model	Spring Torque Start/Min./End (Nm)	Operating Pressure (Bar)											
		3	3.5	4	5	5.5	6	7	8	9	10	11	
		Pressure Torque Output Start/Min./End (Nm)											
CBB525 SR40	Start	187	210	267	324	437	493	550	663	776	890	1003	
	Min.	69	86	115	144	202	231	260	317	374	432	489	
	End	107	134	191	248	361	417	474	587	700	814	927	
CBB525 SR60	Start	286		215	272	387	445	502	617	732	846	961	
	Min.	111		75	108	172	204	235	298	361	424	487	
	End	155		85	143	259	317	375	492	608	725	841	
CBB525 SR80	Start	343				329	386	443	558	673	788	903	1017
	Min.	146				121	153	185	248	311	373	435	498
	End	190				148	208	268	387	507	627	746	866
CBB525 SR100	Start	522						391	509	627	745	862	980
	Min.	189						141	208	274	339	404	469
	End	252						166	290	415	539	663	787
CBB725 SR40	Start	356	436	552	669	903	1020	1137	1370				
	Min.	145	175	236	297	419	479	539	658				
	End	185	281	407	534	786	912	1038	1291				
CBB725 SR60	Start	593		403	514	735	846	956	1178	1399			
	Min.	238		147	217	351	417	483	614	745			
	End	312		158	284	537	663	789	1042	1294			
CBB725 SR80	Start	833				610	719	828	1046	1264			
	Min.	320				253	322	391	527	662			
	End	376				307	435	563	818	1074			
CBB725 SR100	Start	1071						786	1016	1247			
	Min.	368						251	384	511			
	End	482						260	506	752			
Actuator Model	Spring Torque Start/Min./End (Nm)	Pressure Torque Output Start/Min./End (Nm)											
		3	3.5	4	5	5.5	6	7	8	9	10	11	
		Operating Pressure (Bar)											



www.Bettis.com

Copyright © Emerson Process Management. The information in this document is subject to change without notice. Updated data sheets can be obtained from our website www.bettis.com or from your nearest Valve Automation Center. USA: +1 281 727 5300 Europe: +31 74 256 1010 Asia-Pacific: +65 6501 4600



Data sheet

Sheet No.: CBPM 2.01 RevB

Date: February 2010

CBB-Series

Performance Data – (Pneumatic)

Double-Acting Actuators

CBB-Series

Actuator Model	Volume				Maximum Operating Pressure (MOP)*		Maximum Allowable Working Pressure (MAWP)**		Approximate Weight of Actuator	
	Outboard		Inboard (Housing)		PSIG	Bar	PSIG	Bar	Lbs.	Kg
	Cu. Inches	Cubic Cm	Cu. Inches	Cubic Cm						
CBB 315	24	393.3	54	885.0	120	8.3	200	13.8	20	9.1
CBB 420	53	868.5	115	1884.5	120	8.3	200	13.8	22	10.0
CBB 520	83	1360.1	148	2425.3	70	4.8	160	11.0	28	12.7
CBB 525	105	1720.6	207	3392.1	120	8.3	200	13.8	44	20.0
CBB 725	208	3408.5	327	5358.6	80	5.5	160	11.0	68	31.0

Spring-Return Actuators

CBB-Series

Actuator Model	Volume		Maximum Operating Pressure (MOP)*		Maximum Allowable Working Pressure (MAWP)**		Approximate Weight of Actuator	
	Cu. Inches	Cubic Cm	PSIG	Bar	PSIG	Bar	Lbs.	Kg
◆ CBB 315-SR40 SR60 SR80 SR100	54	885	155	10.7	200	13.8	22	10.0
	54	885	152	10.5	200	13.8	23	10.4
	54	885	150	10.3	200	13.8	26	11.8
	54	885	164	11.3	200	13.8	25	11.4
◆ CBB 415-SR40 SR60 SR80 SR100	75	1229	100	6.9	160	11.0	27	12.7
	75	1229	112	7.7	160	11.0	29	14.1
	75	1229	117	8.1	160	11.0	30	14.1
	75	1229	114	7.9	160	11.0	31	14.1
◆ CBB 420-SR40 SR60 SR80 SR100	115	1884.5	157	10.8	200	13.8	37	16.8
	115	1884.5	156	10.8	200	13.8	39	17.7
	115	1884.5	161	11.0	200	13.8	40	18.1
	115	1884.5	166	11.4	200	13.8	41	18.6
◆ CBB 520-SR40 SR60 SR80 SR100	148	2425.3	110	7.6	160	11.0	45	20.4
	148	2425.3	116	8.0	160	11.0	48	21.8
	148	2425.3	120	8.3	160	11.0	49	22.2
	148	2425.3	132	9.1	160	11.0	53	24.0
◆ CBB 525-SR40 SR60 SR80 SR100	207	3392	146	10.1	200	13.8	62	28.1
	207	3392	151	10.4	200	13.8	65	29.5
	207	3392	159	11.0	200	13.8	65	29.5
	207	3392	163	11.2	200	13.8	67	30.4
◆ CBB 725-SR40 SR60 SR80 SR100	327	5358.6	102	7.0	160	11.0	97	44.0
	327	5358.6	115	8.0	160	11.0	98	44.5
	327	5358.6	124	8.6	160	11.0	104	47.2
	327	5358.6	124	8.6	160	11.0	107	48.5

Notes:

- ◆ CBA-SRXXM mechanical handwheel overrides are available on these models. The override adds approximately 2 lbs. (.8 kg) to the weight of the standard CBA model.
 - ▲ Maximum volume including cavity required for calculating consumption per stroke.
 - * **Maximum Operating Pressure (MOP)** is the pressure required to produce the maximum rated torque of the actuator.
 - ** **Maximum Allowable Working Pressure (MAWP)** is the maximum static pressure that may be applied to a fully stroked actuator against the travel stops.
- Standard installation produces clockwise rotation when the outboard side of piston is pressurized.
 Standard installation produces counterclockwise rotation when the inboard side of piston is pressurized.
 Note: Actuator may be installed opposite of that shown above

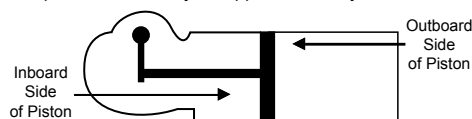

BETTIS[™]

www.Bettis.com

Copyright © Emerson Process Management. The information in this document is subject to change without notice.
 Updated data sheets can be obtained from our website www.bettis.com or from your nearest Valve Automation Center.
 USA: +1 281 727 5300 Europe: +31 74 256 1010 Asia-Pacific: +65 6501 4600

EMERSON[™]
 Process Management

Data sheet

Sheet No.: CBPM 3.01 Rev D

Date: August 2012

CBB-Series

Dimensions – (Pneumatic) mm.

Double-Acting Actuators CBBXXX

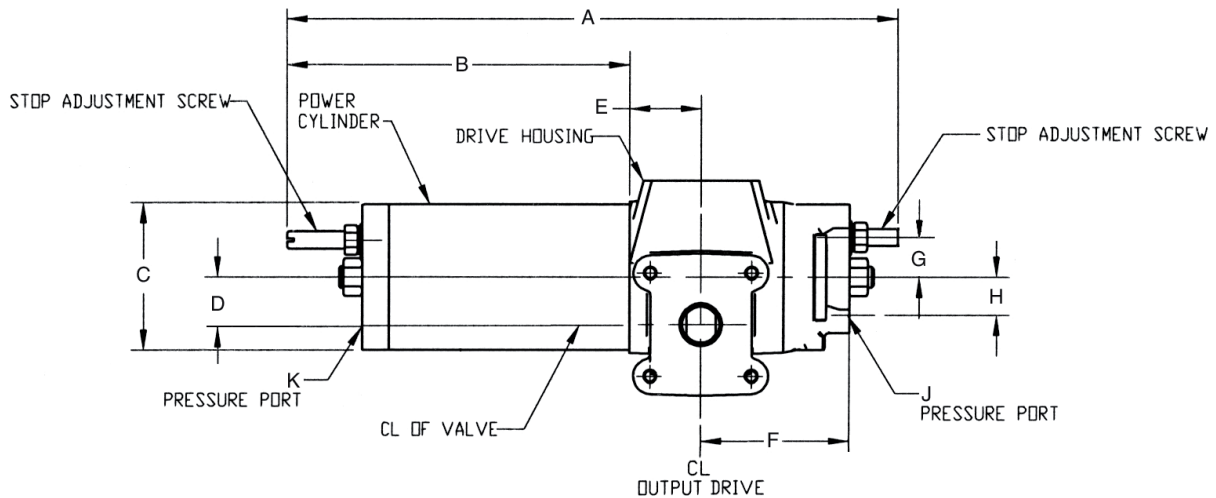

Actuator Model	A	B	C	D	E	F	G	H	J/K	L	M	N
CBB315	359.8	187.5	82.6	27.8	47.8	87.8	23.8	23.9	1/4" NPT	.313-18 UNC	9.7	57.2
CBB420	417.3	217.6	108.0	34.9	54.1	111.0	27.9	27.9	3/8" NPT	.375-16 UNC	12.7	76.2
CBB520	418.1	219.2	136.7	34.9	53.5	111.0	27.9	27.9	3/8" NPT	.375-16 UNC	12.7	76.2
CBB525	488.1	250.9	136.7	42.9	65.0	127.0	31.8	28.4	3/8" NPT	.500-13 UNC	12.7	88.9
CBB725	492.7	260.1	190.5	42.9	64.2	127.0	31.8	28.4	3/8" NPT	.500-13 UNC	12.7	88.9

Actuator Model	P	Q	R	S	T	U	V	W	X	Y	Z	AA
CBB315	.313-18 UNC	28.6	73.8	147.6	19.1	56.4	131.5	15.60 15.75	26.2	95.3	27.8	22.17 22.23
CBB420	.375-16 UNC	38.1	85.1	169.9	19.1	71.3	158.9	21.95 22.10	26.2	117.5	35.1	28.52 28.58
CBB520	.375-16 UNC	38.1	85.1	169.9	19.1	71.3	158.9	21.95 22.10	26.2	117.5	35.1	28.52 28.58
CBB525	.500-13 UNC	44.5	111.1	222.3	28.4	88.9	192.6	28.32 28.47	38.1	146.1	42.9	38.05 38.10
CBB725	.500-13 UNC	44.5	111.1	222.3	28.4	88.9	192.6	28.32 28.47	38.1	146.1	42.9	38.05 38.10

Note: Not Certified dimensional drawings. Such drawings available on request.
Contact factory with correct model designation and serial number.
All dimensions are expressed in millimeters.

BETTIS[™]

www.Bettis.com

Copyright © Emerson Process Management. The information in this document is subject to change without notice.
Updated data sheets can be obtained from our website www.bettis.com or from your nearest Valve Automation Center.
USA: +1 281 727 5300 Europe: +31 74 256 1010 Asia-Pacific: +65 6501 4600

EMERSON[™]
Process Management

Data sheet

Sheet No.: CBPM 3.02 RevC

Date: September 2011

CBB-Series

Dimensions – (Pneumatic) mm.

Double-Acting Actuators
CBBXXX (cont.)

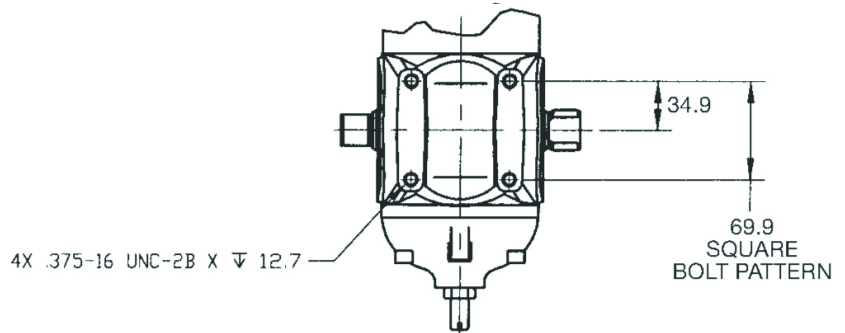

ACTUATORS SHOWN ROTATED
TO FULL CLOCKWISE POSITION

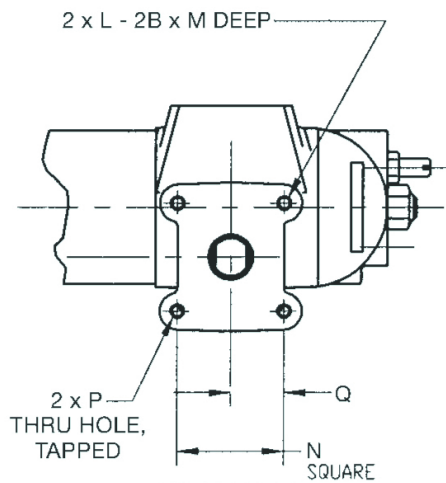

VIEW B-B
VALVE MTG SURFACE
TYP BOLT PATTERN BOTH SIDES
NOTE OPPOSING OUTPUT
SHAFT ORIENTATION

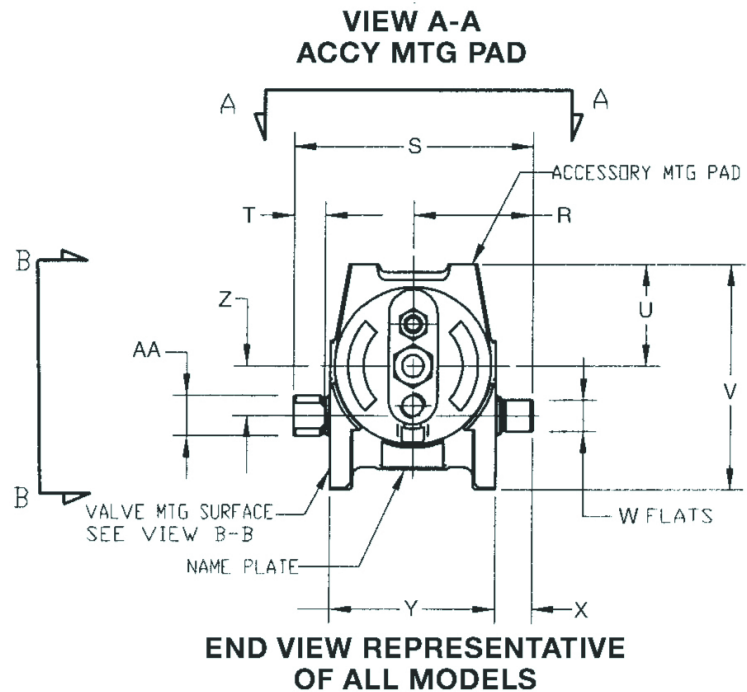

Note: Not Certified dimensional drawings. Such drawings available on request.
Contact factory with correct model designation and serial number.
All dimensions are expressed in millimeters.

BETTIS[™]

www.Bettis.com

Copyright © Emerson Process Management. The information in this document is subject to change without notice.
Updated data sheets can be obtained from our website www.bettis.com or from your nearest Valve Automation Center.
USA: +1 281 727 5300 Europe: +31 74 256 1010 Asia-Pacific: +65 6501 4600

EMERSON[™]
Process Management

Data sheet

Sheet No.: CBPM 3.03 Rev E

Date: January 2013

CBB-Series

Dimensions – (Pneumatic) mm.

Spring-Return Actuators CBB XXX-SRX

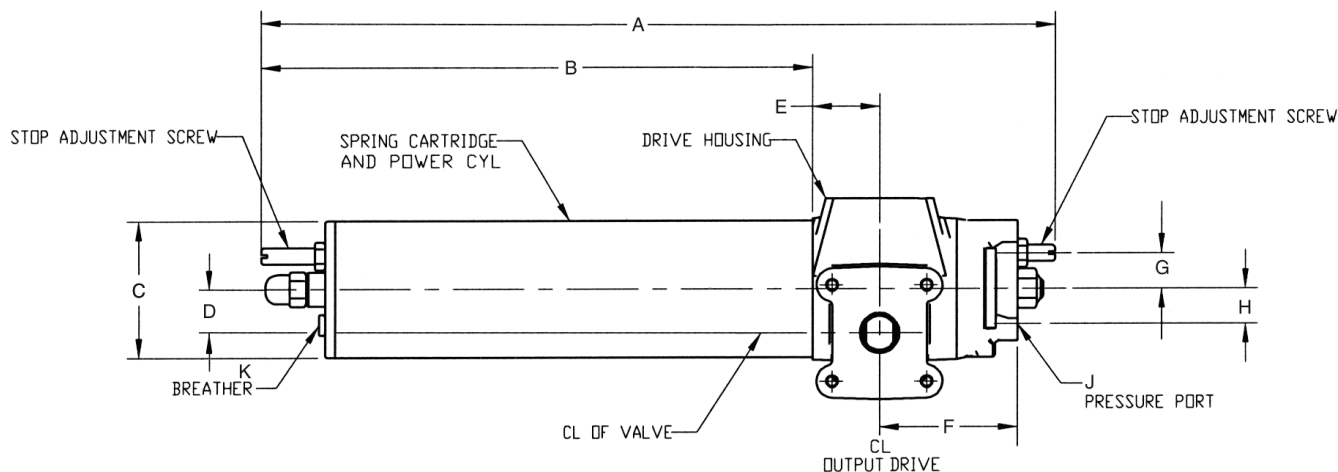

Actuator Model	A	B	C	D	E	F	G	H	J	K	L
CBB315-SRX	511.2	347.0	82.6	27.8	47.8	87.8	23.8	23.9	1/4" NPT	1/4" NPT	.313-18 UNC
CBB415-SRX	513.3	348.2	108.0	27.8	47.8	87.8	23.9	23.9	1/4" NPT	1/4" NPT	.313-18 UNC
CBB420-SRX	623.3	433.5	108.0	34.9	54.1	111.0	27.9	27.9	3/8" NPT	1/4" NPT	.375-16 UNC
CBB520-SRX	631.9	442.9	136.7	34.9	52.2	111.0	27.9	27.9	3/8" NPT	1/4" NPT	.375-16 UNC
CBB525-SRX	716.6	457.4	136.7	42.9	65.0	127.0	31.8	28.4	3/8" NPT	1/4" NPT	.500-13 UNC
CBB725-SRX	713.6	466.7	190.5	42.9	64.2	127.0	31.8	28.4	3/8" NPT	1/4" NPT	.500-13 UNC

Actuator Model	M	N	P	Q	R	S	T	U	V	W	X	Y	Z	AA
CBB315-SRX	9.7	57.2	.313-18 UNC	28.6	73.8	147.6	19.1	56.4	131.5	15.60 15.75	26.2	95.3	27.8	22.17 22.23
CBB415-SRX	9.7	57.2	.313-18 UNC	28.6	73.8	147.6	19.1	56.4	131.5	15.60 15.75	26.2	95.3	27.8	22.17 22.23
CBB420-SRX	12.7	76.2	.375-16 UNC	38.1	85.1	169.9	19.1	71.3	158.9	21.95 22.10	26.2	117.5	35.1	28.52 28.58
CBB520-SRX	12.7	76.2	.375-16 UNC	38.1	85.1	169.9	19.1	71.3	158.9	21.95 22.10	26.2	117.5	35.1	28.52 28.58
CBB525-SRX	12.7	88.9	.500-13 UNC	44.5	111.1	222.3	28.4	88.9	192.6	28.32 28.47	38.1	146.1	42.9	38.05 38.10
CBB725-SRX	12.7	88.9	.500-13 UNC	44.5	111.1	222.3	28.4	88.9	192.6	28.32 28.47	38.1	146.1	42.9	38.05 38.10

Note: Not Certified dimensional drawings. Such drawings available on request.
Contact factory with correct model designation and serial number.
All dimensions are expressed in millimeters.

BETTIS™

www.Bettis.com

Copyright © Emerson Process Management. The information in this document is subject to change without notice.
Updated data sheets can be obtained from our website www.bettis.com or from your nearest Valve Automation Center.
USA: +1 281 727 5300 Europe: +31 74 256 1010 Asia-Pacific: +65 6501 4600



EMERSON™

Process Management

Data sheet

Sheet No.: CBPM 3.04 RevC

Date: September 2011

CBB-Series

Dimensions – (Pneumatic) mm.

Spring-Return Actuators

CBB XXX-SRX (cont.)

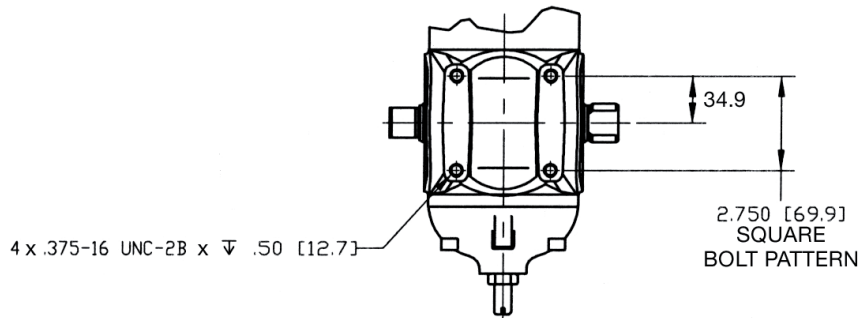

ACTUATORS SHOWN ROTATED
TO FULL CLOCKWISE POSITION

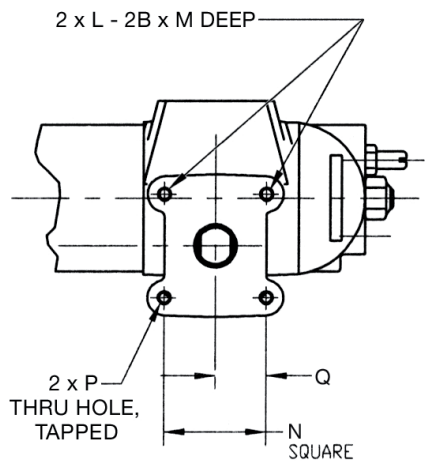

VIEW B-B
VALVE MTG SURFACE
TYP BOLT PATTERN BOTH SIDES
NOTE OPPOSING OUTPUT
SHAFT ORIENTATION

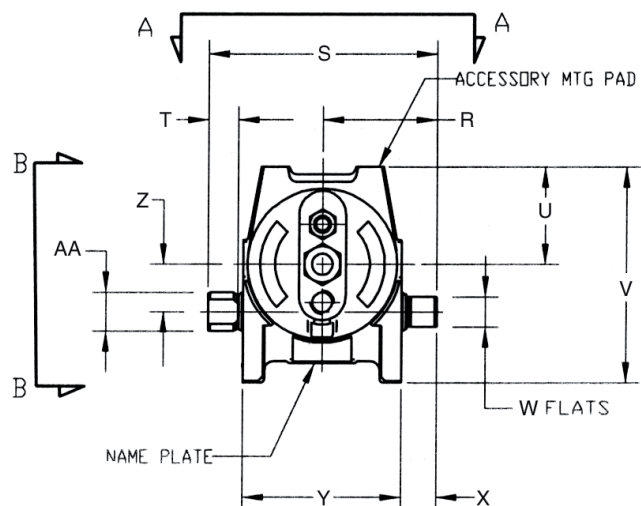

END VIEW REPRESENTATIVE
OF ALL MODELS

Note: Not Certified dimensional drawings. Such drawings available on request.
Contact factory with correct model designation and serial number.
All dimensions are expressed in millimeters.

BETTIS™

www.Bettis.com

Copyright © Emerson Process Management. The information in this document is subject to change without notice.
Updated data sheets can be obtained from our website www.bettis.com or from your nearest Valve Automation Center.
USA: +1 281 727 5300 Europe: +31 74 256 1010 Asia-Pacific: +65 6501 4600

EMERSON™
Process Management

Data sheet

Sheet No.: CBPM 3.05 RevC

Date: September 2011

CBB-Series

Dimensions – (Pneumatic) mm.

M3(HW) Override

Double-Acting Actuators

CBB XXX-M3(HW)

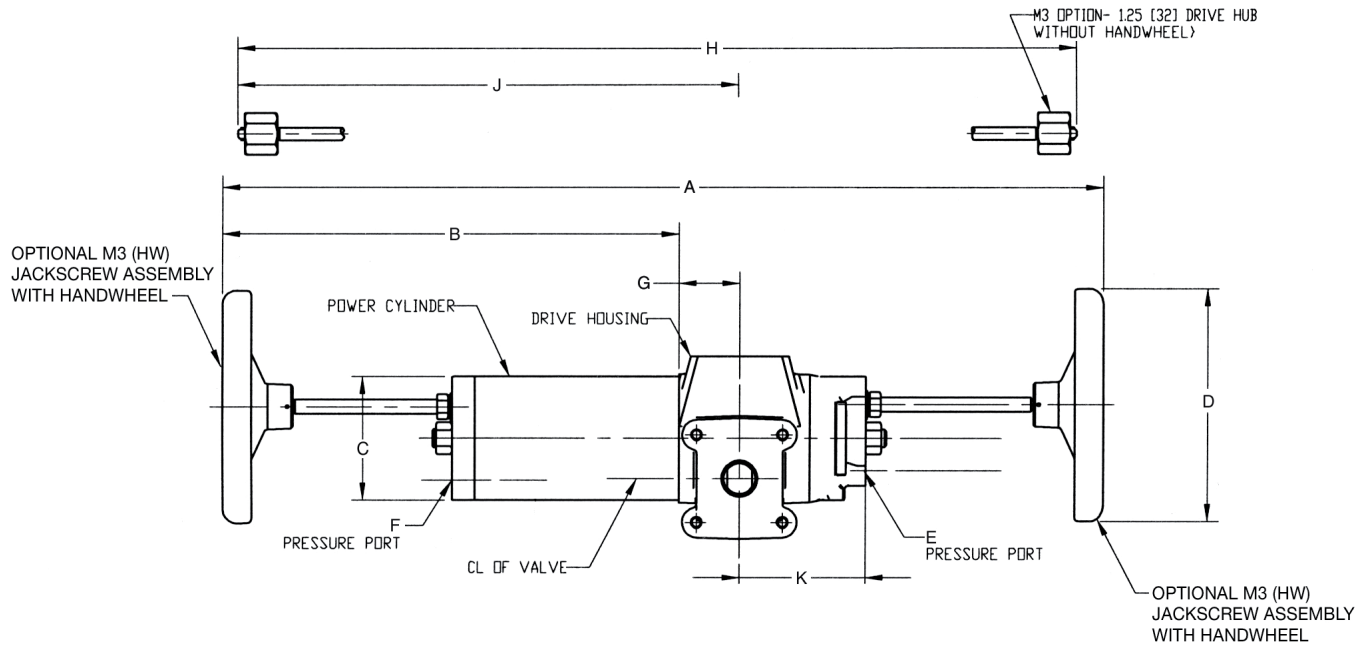

Actuator Model	A	B	C	D	E	F	G	H	J	K
CBB315-M3HW	640.8	365.0	82.6	152.4	1/4" NPT	1/4" NPT	47.6	614.9	365.0	88.2
CBB420-M3HW	776.8	401.8	108.0	203.2	3/8" NPT	3/8" NPT	54.0	739.6	441.1	111.1
CBB520-M3HW	776.8	402.5	133.4	203.2	3/8" NPT	3/8" NPT	53.2	738.0	441.1	111.1
CBB525-M3HW	927.5	480.5	133.4	254.0	3/8" NPT	3/8" NPT	65.0	867.9	515.8	127.0
CBB725-M3HW	930.8	484.6	190.5	254.0	3/8" NPT	3/8" NPT	64.2	867.9	515.8	127.0

Note: Not Certified dimensional drawings. Such drawings available on request.
 Contact factory with correct model designation and serial number.
 All dimensions are expressed in millimeters.

BETTIS[™]

www.Bettis.com

Copyright © Emerson Process Management. The information in this document is subject to change without notice.
 Updated data sheets can be obtained from our website www.bettis.com or from your nearest Valve Automation Center.
 USA: +1 281 727 5300 Europe: +31 74 256 1010 Asia-Pacific: +65 6501 4600

EMERSON[™]
 Process Management

Data sheet

Sheet No.: CBPM 3.06 RevC

Date: September 2011

CBB-Series

Dimensions – (Pneumatic) mm.

M3(HW) Override

Spring-Return Actuators

CBB XXX-SRX-M3

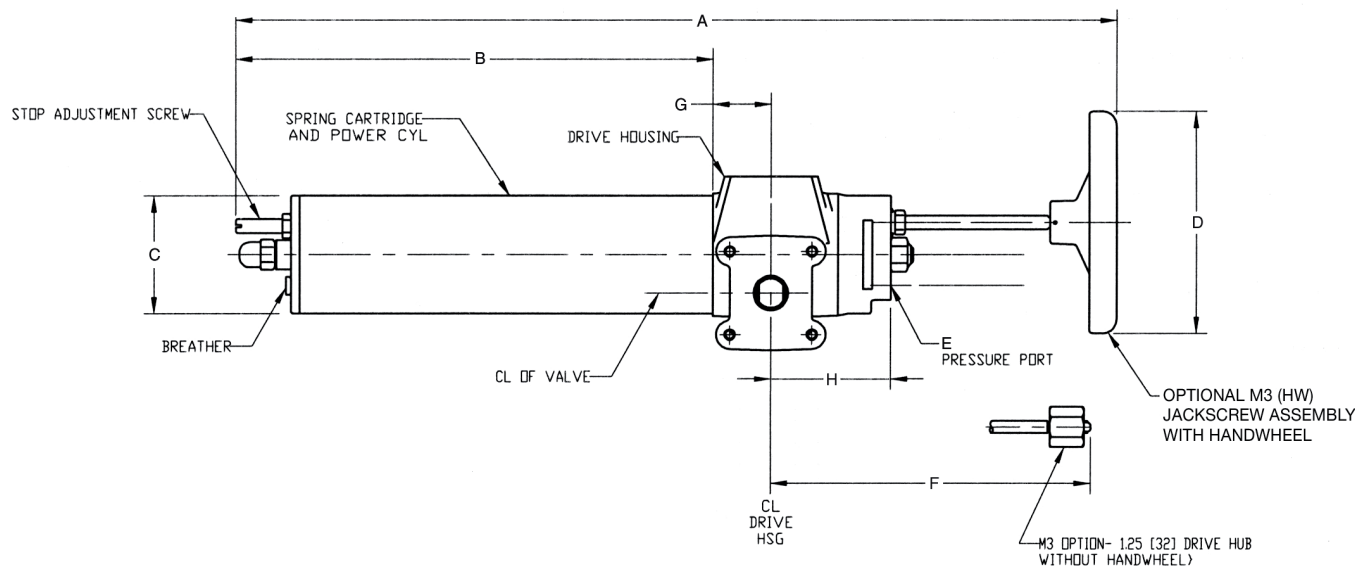

Actuator Model	A	B	C	D	E	F	G	H
CBB315-SR-M3HW	677.1	366.5	82.6	152.4	1/4" NPT	249.9	47.6	88.2
CBB415-SR-M3HW	679.1	368.6	108.0	152.4	1/4" NPT	249.9	47.6	88.2
CBB420-SR-M3HW	816.2	441.3	108.0	203.2	3/8" NPT	297.0	54.0	111.1
CBB520-SR-M3HW	816.8	442.7	136.7	203.2	3/8" NPT	297.0	53.2	111.1
CBB525-SR-M3HW	937.9	491.0	136.7	254.0	3/8" NPT	351.9	65.0	127.0
CBB725-SR-M3HW	939.2	493.1	190.5	254.0	3/8" NPT	352.1	64.2	127.0

Note: Not Certified dimensional drawings. Such drawings available on request.

Contact factory with correct model designation and serial number.

All dimensions are expressed in millimeters.

BETTIS[™]

www.Bettis.com

Copyright © Emerson Process Management. The information in this document is subject to change without notice.

Updated data sheets can be obtained from our website www.bettis.com or from your nearest Valve Automation Center.

USA: +1 281 727 5300 Europe: +31 74 256 1010 Asia-Pacific: +65 6501 4600

EMERSON[™]
Process Management

Contact Us: Emerson Process Management, Valve Automation facilities at your nearest location:

NORTH & SOUTH AMERICA

9200 Northwest Freeway
Houston Texas 77065
USA
T +1 281 727 5300
F +1 281 727 5353

2500 Park Avenue West
Mansfield, OH 44906
USA
T +1 419 529 4311
F +1 419 529 3688

9009 King Palm Drive
Tampa, FL 33619
USA
T +1 813 630 2255
F +1 813 630 9449

13840 Pike Road
Missouri City, Texas 77489
USA
T +1 281 499 1561
F +1 281 499 8445

Av. Hollingsworth,
325, Iporanga Sorocaba,
SP 18087-105
Brazil
T +55 15 3238 3788
F +55 15 3228 3300

MIDDLE EAST & AFRICA

P. O. Box 17033
Dubai
United Arab Emirates
T +971 4 811 8100
F +971 4 886 5465

P. O. Box 105958
Abu Dhabi
United Arab Emirates
T +971 2 697 2000
F +971 2 555 0364

P. O. Box 3911
Al Khobar 31952
Saudi Arabia
T +966 3 814 7560
F +966 3 814 7570

P.O. Box 10305
Jubail 31961
Saudi Arabia
T +966 3 340 8650
F +966 3 340 8790

P. O. Box 32281
Doha
Qatar
T +974 4 576777
F +974 4 315448

24 Angus Crescent
Longmeadow Business Estate East
P.O. Box 6908; Greenstone; 1616
Modderfontein, Extension 5
South Africa
T +27 11 451 3700
F +27 11 451 3800

EUROPE

Asveldweg 11
7556 BR Hengelo (O)
The Netherlands
T +31 74 256 1010
F +31 74 291 0938

Siemensring 112
47877 Willich
Germany
T +49 2154 499 660
F +49 2154 499 6613

25, Rue de Villeneuve
Silic – BP 40434
94583 Rungis
France
T +33 1 49 79 73 00
F +33 1 49 79 73 99

Via Montello 71/73
20038 Seregno (Milan)
Italy
T +39 0362 2285 207
F +39 0362 2436 55

6 Bracken Hill
South West Industrial Estate
Peterlee SR8 2LS
United Kingdom
T +44 191 518 0020
F +44 191 518 0032

2A Szturmowa Str
02-678 Warsaw
Poland
T +48 22 45 89 237
F +48 22 45 89 231

C/ Francisco Gervás, 1
28108 Alcobendas – Madrid
Spain
T +34 0913 586 000
F +34 0913 589 145

Letnikovskaya Str. 10-2
115114 Moscow
Russia and FSU
T +7 495 981 98 11
F +7 495 981 98 10

ASIA PACIFIC

No. 9 Gul Road
#01-02 Singapore 629361
T +65 6501 4600
F +65 6268 0028

9/F Gateway Building
No. 10 Ya Bao Road
Chaoyang District
Beijing 100020
P.R.China
T +86 10 5821 1188
F +86 10 5821 1100

No.15 Xing Wang Road
Wuqing Development Area
Tianjin 301700
P.R.China
T +86 22 8212 3300
F +86 22 8212 3308

Lot 13112, Mukim Labu
Kawasan Perindustrian Nilai
71807 Nilai, Negeri Sembilan
Malaysia
T +60 6 799 2323
F +60 6 799 9942

471 Mountain Highway
Bayswater, Victoria 3153
Australia
T +61 3 9721 0200
F +61 3 9720 0588

Delphi B Wing, 601 & 602
6th Floor, Central Avenue
Powai, Mumbai – 400 076
India
T +91 22 6662 0566
F +91 22 6662 0500

NOF, Shinagawa Konan Bldg
1-2-5, Higashi-shinagawa
Shinagawa-ku, Tokyo
140-0002 Japan
T +81 3 5769 6873
F +81 3 5769 6902



www.globalsupplyline.com.au

Global Supply Line are Bettis resellers and stockists. We are an approved Emerson Actuator distributor. We can supply/ quote complete actuator packages for emergency supply within Australia, New Zealand, Papua New Guinea and all overseas locations from our Adelaide Emerson Approved Automation Centre. [Click here](#) for our full on line stock list.

All rights reserved.

No part of this publication may be copied or published by means of printing, photocopying, microfilm or otherwise without prior written consent of Emerson Process Management. This restriction also applies to the corresponding drawings and diagrams.

Emerson Process Management has the right to change parts of the machine at any time without prior or direct notice to the client. The contents of this publication are subject to change without notice.

This publication is to be used for the standard version of the machine only. Thus Emerson Process Management cannot be held responsible for any damage resulting from the application of this publication to the version actually delivered to you.

For extra information as to adjustments, maintenance and repair, contact the technical department of your supplier.

This publication has been written with great care. However, Emerson Process Management cannot be held responsible, either for any errors occurring in this publication or for their consequences.

©2013 Emerson Electric Co.

BETTIS

www.Bettis.com



EMERSON
Process Management