

TRUNNION MOUNTED BALL VALVES FOR SOLAR PLANTS

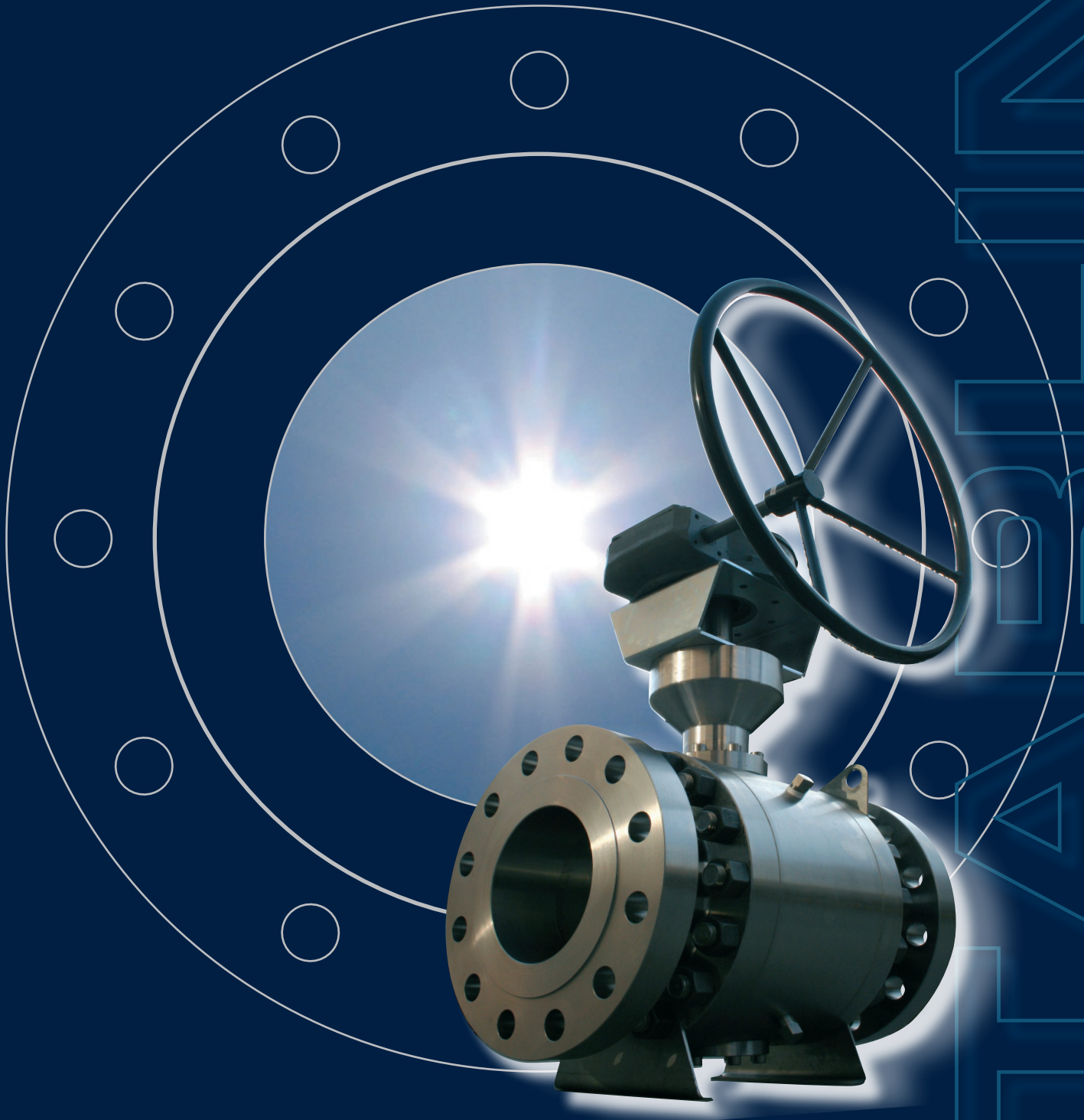

st STARLINE[®]
forged steel ball valves

Global Supply Line are the sole agents & stockists for Australia, New Zealand and Papua New Guinea
www.globalsupplyline.com.au



TRUNNION MOUNTED BALL VALVES FOR SOLAR PLANTS

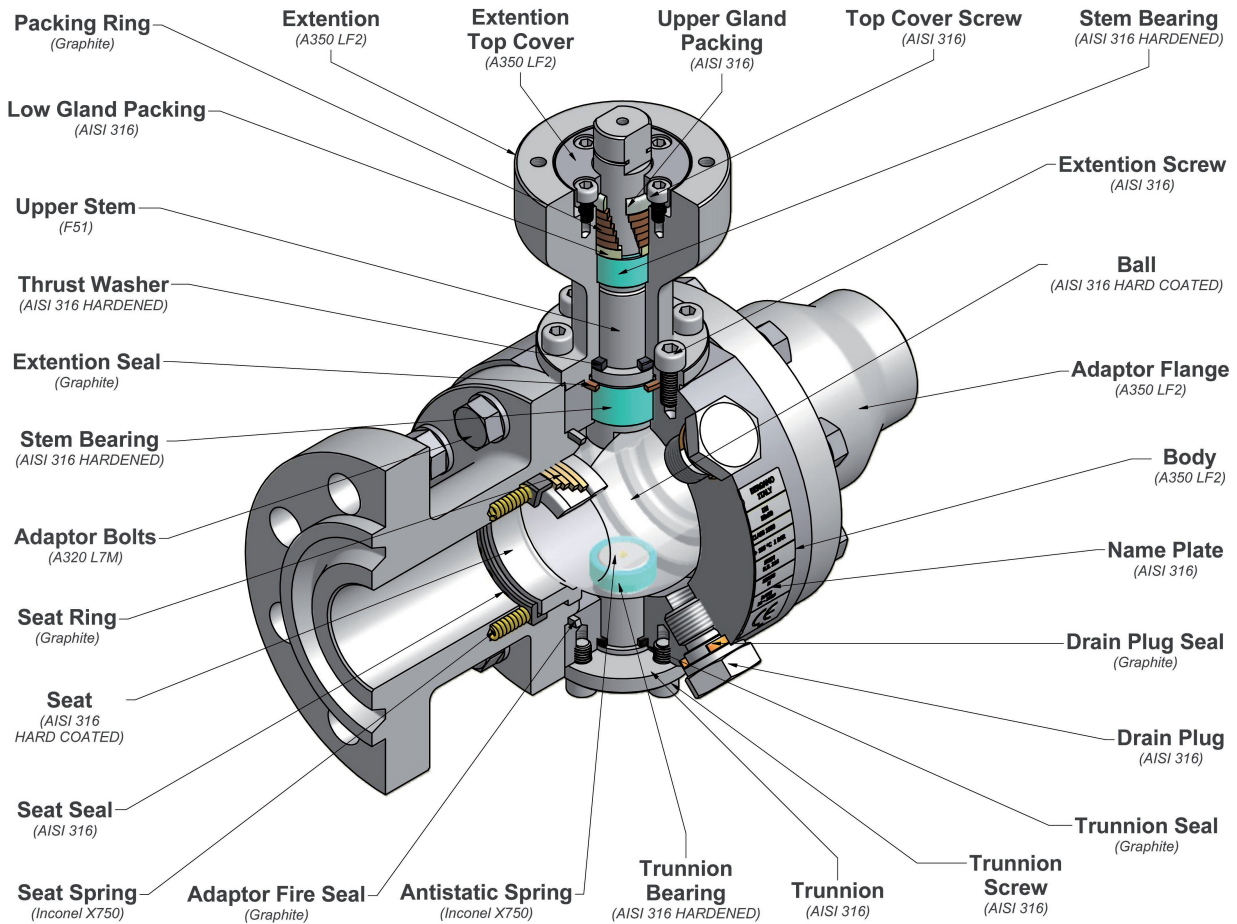

FLANGED RF/RTJ

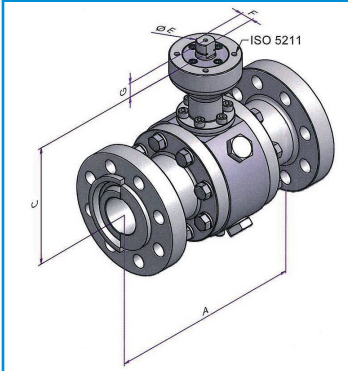

WELDING ENDS

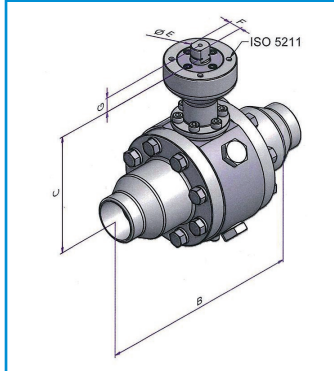

TRUNNION MOUNTED HIGH TEMPERATURE

- Three pieces bolted construction – modular end connections available in any kind of execution
- FULLY MADE IN ITALY product – guaranteed quality
- Antistatic Antiblowout stem
- Metal seated with 150 microns hard Chrome Carbide HVOF Coating – available also with 400 microns coating
- Full tightness with zero leakage guaranteed (gas tested)
- Optional materials for higher corrosion resistance
- Valve internal protection with phosphating treatment
- High temperature paint system available on request
- Full construction to ISO 14313
- Face to face dim to ASME B16.10
- Easy automation with ISO 5211 top flange
- SIL 3 certification
- ISO 15848 / TA LUFT certification for low emission

DN	Inch	Dimensions [mm]							ISO 5211
		A	B	C	Bore	E	F	G	
50	2"	216/292	292	170.5	50	24	18	21	F07
80	3"	283/356	256	197	76	24	18	20	F07
100	4"	305/432	432	282	100	40	30	31	F10

** other sizes and pressure ratings available on request

